

The magazine of  
Willamette University  
Spring 2016

# *Willamette*

A group of women in traditional Hawaiian attire, including white dresses with blue and green floral patterns and white leis, are performing on a stage. They have their arms raised in a gesture of celebration or dance. The background features a large mural of a tropical scene with a sun, palm trees, and flowers. Stage lights are visible above the performers.

**Inside: Bearcat mentors offer career and life wisdom; Alumnae tackle the dark side of video games; A student meditates on his research trip to China. And, can America's shared garment of destiny be saved?**



**After touring Washington, Idaho and Montana in January, the Willamette Singers gave a spectacular homecoming performance in Hudson Hall.**

**A cookie from The Bistro is a sweet treat in the midst of a busy Willamette afternoon — but this spring a newly named confection became a symbol of something more meaningful and perhaps even profound.**



*President Steve Thorsett chats with students during the Bowties in The Bistro event in February.*

Named the “Schmidty” in honor of our director of campus recreation, Bryan Schmidt, the new type of cookie features M&M’s, peanut butter and chocolate chips.

This honor has occurred only once before in the coffee shop’s 30-year history — with the creation of the “Buzz Bar” in honor of Richard “Buzz” Yocum ’49, based on a recipe from his wife, Libby Yocum, a former faculty member.

Bryan’s cookie recognizes the incredible program he’s built during his decade-long tenure at Willamette. We welcome countless students from the Northwest and beyond who want to experience the natural wonders of the place we call home and to build community. Trips through the Outdoor Program, a wide selection of club and intramural sports, and — launching this spring — a new wellness program for the Willamette community are a few of the amazing programs that have flourished under Bryan’s leadership.

Indeed, student activities and involvement at Willamette go far beyond what’s typical at most colleges. That’s because at Willamette, you can start something new if you have passion and initiative.

Some student-run enterprises, like The Bistro and Bike Shop, are essential elements of our campus culture. And through Willamette’s 100-plus student organizations (a few of which are profiled beginning on p. 16), great ideas and opportunities for learning and service emerge every day.

Countless examples also exist of students who expand and enrich their co-curricular or academic experiences by forging their own paths. They design their own unique research or experiential projects through grants, service learning or collaboration with faculty. And in doing so, they make a tremendous impact in the community and to their respective disciplines.

Take Rei Ayala ’14 and Rey Goicochea ’13, who started a poetry class in a local penitentiary to encourage creativity and help prisoners make better decisions about their lives. Or consider Maya Kaup ’17, one of my former advisees, who used a Carson undergraduate research grant to enhance her interest in conservation and behavioral ecology — areas of critical importance in the natural world we steward.

A crucial element in such success is the individualized advice, support and guidance that students receive here. Mentorship comes naturally to our professors, staff and alumni. Our feature, “The Mentor Effect” on p. 8, showcases some of the professors and alumni who willingly share their time, efforts and life wisdom with other members of the Bearcat community.

Many of these alumni have their own success stories to tell. They are civic leaders, entrepreneurs, community advocates and unsung heroes living our motto around the world.

A little less than a year from now we’ll kick off celebrations for Willamette’s 175th anniversary. During this milestone year we hope to tell the Willamette story through the voices of our community — and we want to hear from you. I invite you to share your stories and memories with us by e-mailing [magazine@willamette.edu](mailto:magazine@willamette.edu).

Non nobis solum nati sumus,

A handwritten signature in black ink that reads "Stephen E. Thorsett". The signature is fluid and cursive, with the first letters of the first and last names being capitalized and prominent.

Stephen E. Thorsett  
President



Willamette students help construct a Habitat for Humanity home as part of the university's Into the Streets community service events during this year's MLK Celebration.

**05**  
**Meditations on a trip to China**

**Cover**

Willamette's annual student-produced lu'au showcases the warmth and culture of Hawai'i to the community.

**06**  
**A man with a vision — and stories to tell**

**Features**

**08**  
**The Mentor Effect**

At Willamette, faculty, staff, students and alumni willingly share their skills, experience and advice to help other Bearcats find their paths through college, careers or life.

**16**  
**Of Fire Dancers and Fantasy Lands**

What do Willamette students do in their spare time? What *don't* they do? We profile a few of the 100 co-curricular clubs and organizations that offer friendship, community and opportunities to explore new activities and causes.

**26**  
**Game Changers**

Three alumni fight back against the rampant discrimination and sexism they encountered in the video gaming and tech industries.

**Departments**

- 01 Not Unto Ourselves Alone**
- 04 In Box**
- 05 In Conversation**
- 06 Tools of My Trade**
- 14 Streaming Now**
- 22 Made by Hand**
- 24 4 to Watch**
- 25 Then & Now**
- 34 On Location**
- 36 Cardinal & Gold**
- 40 Well Read**
- 41 Bearcat World**
- 56 In My Humble Opinion**

**56**  
**Inspired by Martin Luther King Jr., lessons on our shared destiny**

**Magazine Team**

- Publisher:** Michael Beseda
- Associate Publisher:** Russell Yost MBA'05
- Editor:** Tina Owen
- Creative Director:** Mike Wright
- Graphic Designers:** Susan Blettel, Mike Wright
- Photographer:** Frank Miller
- Web Developers:** Timothy Gilman, Brian Hoyt, Laura Levin, Tonya Wheeler
- Contributors:** Erin Dahl, Sarah Evans, Melissa Gallardo, Scott Johnson, Lyra Kuhn '16, James Lippincott, Robert McKinney, Frank Miller, Star Nicholson, Alex Paraskevas, Stephen E. Thorsett, Adam Torgerson MBA'14
- Class Notes Editor:** Daniel Johnson

Willamette, the magazine of Willamette University, is published three times each year by University Communications. Its purpose is to share stories and conversations that help alumni and friends stay meaningfully connected to the university.

The views presented in Willamette do not necessarily reflect the opinions of the editors or the official policies and positions of Willamette University.

Send address and name corrections to [magazine@willamette.edu](mailto:magazine@willamette.edu)



Printed on FSC® certified paper with vegetable based inks.

## >In Box

I read with considerable interest the obituary for Ann Rule, “Prolific Author Leaves Legacy in True Crime Genre,” in the fall 2015 issue of Willamette magazine. Yes, Ann (Stackhouse) Rule was indeed an outstanding writer and a credit to Willamette. But there was no mention in the article that she was the daughter of famed Chester Stackhouse, Willamette’s director of athletics and head football and track coach from 1949-52.

Chester Stackhouse was inducted into the university’s Athletic Hall of Fame in 1992. He was the founder of the Willamette Relays, which brought together several hundred high school and college athletes to compete in a well-organized track meet at McCulloch Stadium. The event began in 1951 and was held annually for 36 years.

During Chester’s tenure, the track team won 42 of 46 dual meets and garnered the Northwest Conference championship in 1951 and ’52. Chester was a very innovative person — an inventor of athletic equipment and a superb organizer of both track and football contests. He was a very kind man and took great interest in his athletes. He had a lasting impact on those, like myself, who knew him. Chester died in 1978.

— Donald Empey ’54

I am disappointed, but not surprised, to read “The Challenge of Our Generation” in the last magazine. Unfortunately, this article and most of the general media have become one-sided in their reporting — enamored with the “green” agenda that in many cases is supported by “degrowthers” who believe our way of living is both immoral and unsustainable.

I favor all attempts to find economically viable alternative energy sources by whatever means a free market can and will support. But many of the government-supported projects have been a waste of taxpayer money (e.g. Solyndra) and/or would not survive without subsidies or tax credits (e.g. most wind power and solar projects).

In answer to the article’s subhead — “Can we stop climate change?” — the answer is “no,” because the changing climate is little affected by mankind. It is most likely the climate will change over time, cooling and warming as it has throughout history, affected by conditions over which we mere mortals have little control, such as changing conditions on the sun, the changing attitude of earth on its axis and other conditions not properly represented in current climate forecast models.

I don’t know about you, but our electric bill has increased substantially over the past five years, mainly due to a mandated percentage for uneconomical renewable energy.

— Merlin Schulze ’54

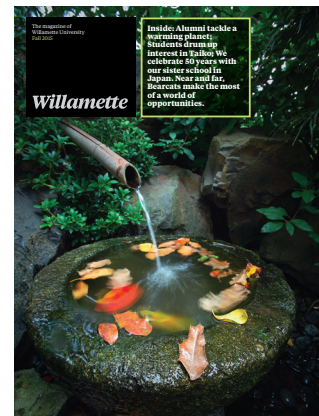

### Where’s Tufton?

Mike Durrell ’64 was the first reader to spot Tufton Beamish’s presence in the last issue — Tufton’s name was scrawled in chalk on the ground near the Red Light/Green Light event pictured on p.32. So now there’s a double challenge: find Tufton hiding somewhere in this magazine — and beat Mike to it! Send your sightings to [magazine@willamette.edu](mailto:magazine@willamette.edu).



**f** *Bearcat alumni recently shared memories via the Willamette University Alumni Association Facebook page ([facebook.com/WillametteAlumni](https://facebook.com/WillametteAlumni)) of the student clubs or organizations they participated in during their time on campus.*

Willamette Chamber Choir.  
I am a professional musician today because of the tremendous and rewarding challenges Dr. Wallace Long presented me and my colleagues with day after day. Thank you, from the bottom of my heart.

— Catherine van der Salm ’96

AFR (we created our own sorority), the Collegian and Wallulah (proofreading and photography), Foreign Affair (a multicultural, international festival), Christian Body and Lausanne ... it was quite a club, living there in the ’70s!

— Susan Elizabeth Marsh  
Tanabe ’79, MAT’90

Intramural wiffleball champs! I have a T-shirt somewhere to prove it!

— Ben Wilson ’05, MAT’06

Willamette Christian Body.

— Mitzi Barker ’75

Mu Phi Epsilon.

— Carol Ratzlaf ’65

Metanoia!

— Lisa Johnson Perez ’91

*To see the interesting — and unusual — activities that Willamette students enjoy in their spare time today, turn to our article, “Of Fire Dancers and Fantasy Lands,” on p. 16.*

## On a research trip to China, politics major Luther Caulkins '16 meditated with Buddhist monks, explored remote regions and realized some hard truths.

### > Why did you go to China?

I received a Carson Grant to spend two months in China last summer, studying the education that monks receive in Buddhist monasteries and what that says more broadly about the values and goals of Buddhism in China.

### > You actually stayed in some monasteries. What was that like?

I stayed in the Hangzhou Buddhist Academy, the Jiangxi Buddhist Academy and the Donglin Temple in northwest China. For my research, I observed the curriculum and methods of instruction. But I also participated in the daily life of the monastery, including getting up at 4:30 a.m. to chant and meditate. Although I'm not a Buddhist, I practice mindfulness meditation at home — but it was challenging to sit cross-legged for 90 minutes at a time at the monastery, especially in the heat and humidity. It was a very dramatic experience. We'd file into the meditation hall, and a monk would strike a large gong. After a walking meditation around the altar with its Buddha statue, we'd go to our mats for sitting meditation. Even though I didn't understand everything that was going on, it was a thrill — and somewhat surreal — to participate in these ancient rituals and cultural traditions.

### > How well is Buddhism accepted by the Chinese authorities?

Even before the Communists took over, Buddhism was the subject of government



scrutiny and persecution, as it was seen as a remnant of ancient times that was holding China back from modernization. The 1980s saw an official shift in government policy, with a number of religions, including Buddhism, recategorized as patriotic. Since then, there's been a growing appreciation of Buddhism as culturally important and an enhancement to national pride and unity. In the shops, I saw statues of Chairman Mao next to statues of the Buddha.

### > You're minoring in Chinese studies at Willamette. What prompted that choice?

It started as a practical decision, because of China's growing power and importance in the global community. Also, I wanted to get away from a myopic Western understanding of the world. But then it grew into a bigger appreciation of China's rich culture and history.

### > What are some of the enduring memories you have of your trip?

Traveling in some of the remote rural areas, I realized that I was probably the first American — at least, a Chinese-speaking American — that these people had seen. Many of these places had scarce electricity, running water or basic infrastructure like good roads. There was no Internet, but there was a lot of poverty. I recognized what inequality looks like. And I was absolutely struck by the fact that the 21st century as the U.S. thinks about it isn't being experienced by the majority of humans. ☐



1

3



Bobby Brewer-Wallin is a storyteller — but instead of words, he conveys messages and meaning through clothing and costumes.

As a costume designer, he can create clothing that shows the changing of seasons and the end of mourning, as well as signal affluence or poverty, innocence or corruption. Fashions track the passage of time and mark historic moments or events.

And in Brewer-Wallin's clever hands, color, fabric and texture can reveal a dramatic character's nature and evolution.

Brewer-Wallin, an associate professor of theatre, has specialized in costume design for about three decades. He started at Lewis & Clark College in Portland, Oregon, where, as a visual arts and religious studies major, he created a Jewish prayer shawl and several liturgical robes as part of his thesis project.

After earning his MFA at the California Institute of the Arts, he worked as an entertainment costumer at Disneyland Resorts and a costume designer for music videos, independent films and main stage productions. He brought his talents to Willamette in 2000.

"What I love about the work is that it's always different," he says. "It allows me to immerse myself in a new time and place, playing into my love for creativity and history."

Each season, Brewer-Wallin designs the costumes for three mainstage plays and one dance concert — making everything from military regalia and livery to kimonos and evening gowns.

A climate-controlled storage room in the recently renovated Pelton Theatre building holds thousands of wigs, shoes, patterns and costumes from previous productions. If he can't find what he needs there, Brewer-Wallin makes something new.

While he designs the costumes and patterns, student interns and volunteers use sewing machines to make the garments.

These are some of the tools essential for their work:

### 1. Image Board

Brewer-Wallin plans his costumes about three months in advance of each production. Using the play's time period, seasons and location as a guide, he researches photos, drawings and paintings and pins color copies to an image board for feedback from the director, scene designer and lighting designer. "When I got into this work 30 years ago, I would go to the library for research," he says. "Although I still browse the stacks in the library, now, with the Internet, I can access images day or night."

### 2. Art Supplies

He starts with a simple pencil sketch of each costume, then selects the fabric. He uses colored pencils and watercolors to add pigment and texture to the drawings, matching the fabric swatches. "I like to think of costume rendering as a means of communication," he says. "It communicates an idea to the director and designers, helps actors imagine what they'll look like on stage, and acts as blueprints for creating the patterns and sewing the garments."

### 3. Fabric Shears

Brewer-Wallin acquired his shears in 1996 while in graduate school. Sharpened every two years, the shears are engraved with his name and adorned with a scrap of fabric so students don't confuse his pair with their own.

### 4. Dress forms

Male and female dress forms help designers see their costumes in three dimensions. Duplicating the cast members' measurements exactly — from their waist circumference to inseam length — the dress forms are padded, if necessary, to achieve the desired sizes. Changes are inevitable, though, especially as actors' measurements may fluctuate during a busy rehearsal schedule. So, Brewer-Wallin and his team stand by for alterations — right up to the last minutes before a show begins.

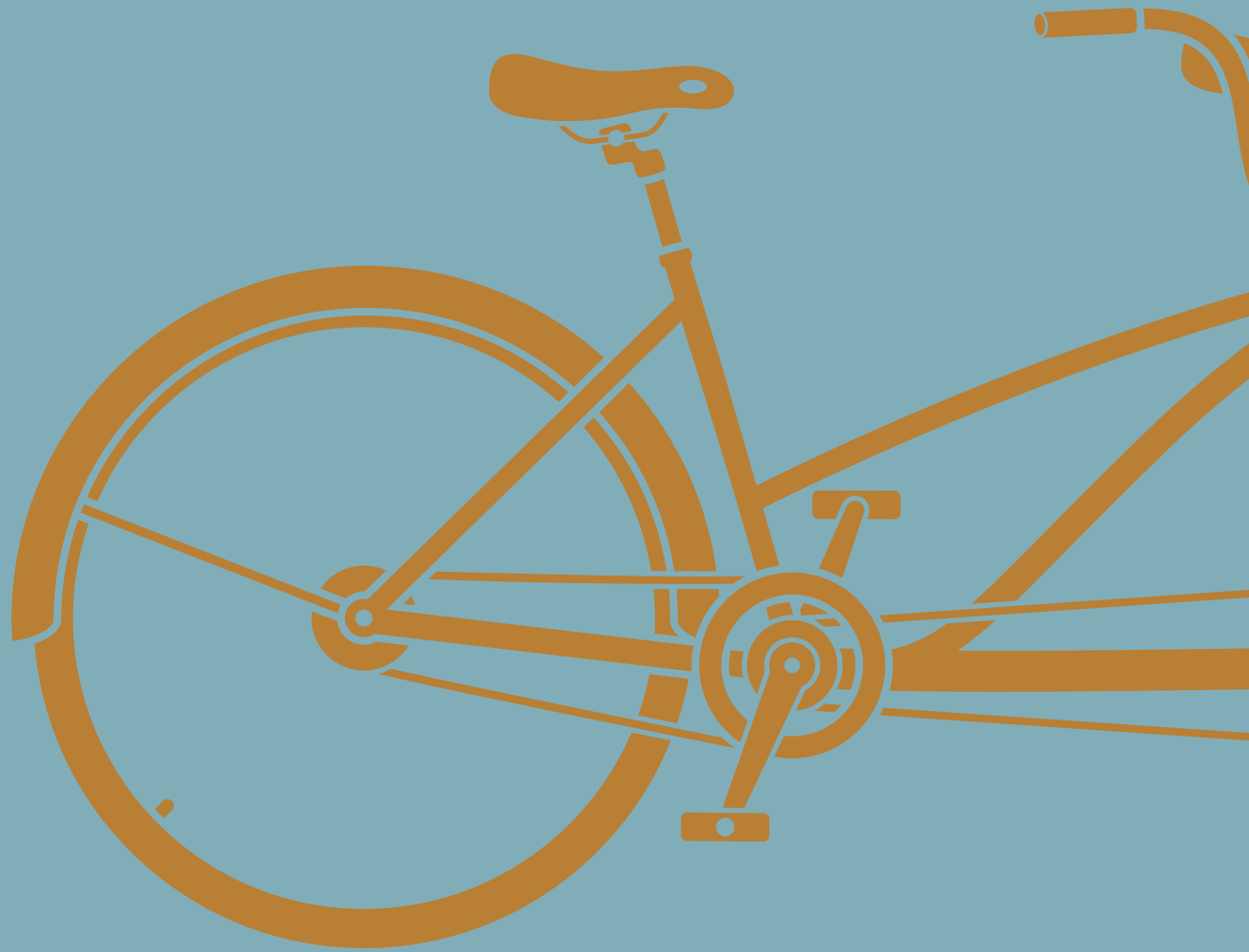

# The Mentor Effect

Sharing their experiences and knowledge to help others find their own paths in the world, mentors are career advisors, cheerleaders and caring friends. And at Willamette, they abound.

by Tina Owen

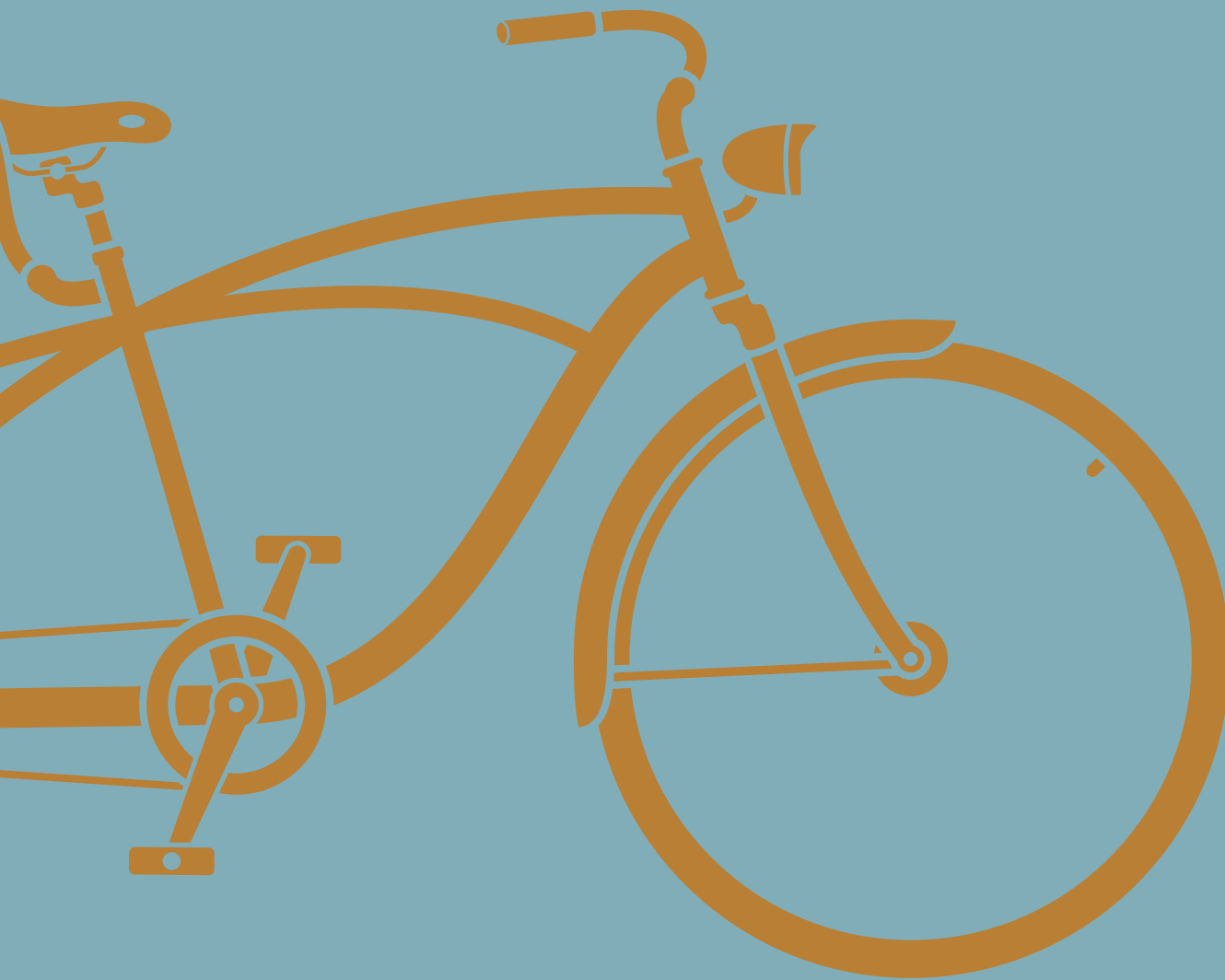

### **Value-Added Teaching**

Students seeking a mentor likely look for an approachable professor who makes them feel comfortable. Rebecca Knight '07 selected exercise science professor Peter Harmer as her advisor and eventually her mentor because “he’s the toughest professor I’ve had in my life.”

Harmer certainly enjoys a reputation as a no-nonsense, hard-driving taskmaster. A stickler for quality work and premium effort, Harmer often returns students’ papers covered with his corrections and comments. High marks are hard-earned in his classes. When one student finally received an A, she proudly sent the paper

home for her mom to display on the refrigerator.

Such dedication to high standards, along with his decades of academic and life experience, also make Harmer an excellent mentor. Students who’ve benefited from his guidance rave about Harmer’s positive effect on their lives and careers. Several of them penned letters in support of the 2015 Mentor of the Year Award he received last fall from the Oregon Medical Research Foundation.

“In a sense, every faculty member is a mentor, even when they’re only teaching the technicalities of a discipline,” says Harmer. “For me, mentoring is value-

added teaching that goes outside the classroom and beyond the constraints of the curriculum.

“It’s about life. Students come and talk to you about career and personal issues, and you use your experience and insights to help them make better decisions.”

In his 26 years at Willamette, Harmer has held countless one-on-one meetings with mentees, often during the evening or weekends. He aims to get to know them so he can offer the best, personalized advice. “You have to be willing to give of your time,” he says. “It’s very gratifying talking to students and helping them work through difficulties. It’s a little bit like being a parent.”

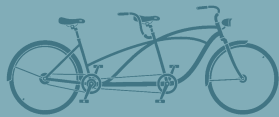

**Rebecca Knight '07** brought her daughter, **Amelia**, to campus to meet her mentor, exercise science professor **Peter Harmer**. Knight credits Harmer's example of dedication to his mentees for inspiring her to become a mentor to her own staff and students. She says, "The goal is to help them succeed in whatever way I can."

**Rachel Kittle** (left) submitted a heartfelt nomination letter on behalf of her mentor, **Concetta Schwesinger**, who won the College of Law's 2006-07 Mentor of the Year Award. She wrote, "[Concetta] believed in me and helped me believe in myself — even when I didn't think that was possible."

The Atkinson Graduate School of Management's mentoring program helped businessman **Warren Bednarz** (left) and MBA student **David Nguyen** from Vietnam find common interests that cut across cultural differences.

Anthropology professor **Joyce Millen** (right) and junior **Hania Mariën** discuss some of the multicultural children's books that inspired Mariën's research.

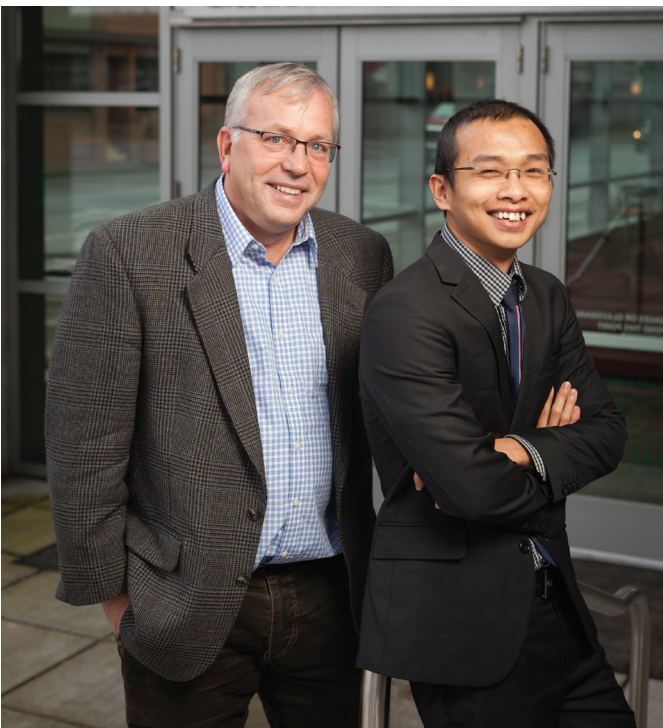

Harmer has provided so many letters of recommendation for students applying to graduate school or for jobs that he keeps track of them all via a large spreadsheet on his computer.

Knight is among the students listed on that spreadsheet. Harmer provided a recommendation that helped Knight, a member of the Confederated Tribes of Grand Ronde, land a fellowship in Washington, DC, working on Native American health issues. Later, he recommended her for her master's degree in public health/health policy and management from the University of Hawaii, her job as program director at the University of Hawaii Cancer Center, and for her recent application for a PhD in public health at Oregon State University.

She also illustrates what Harmer means when he says, "Mentoring happens over the long haul." Harmer typically stays in touch with his mentees long after they leave Willamette, and gradually the professor-student relationship transforms into a friendship.

"He always wants what's best for his students, and he always provides really honest feedback," says Knight, who recently brought her baby daughter, Amelia, to campus to meet her mentor. "I can call him and just talk, or have lunch and have a really open conversation. I'm constantly learning from him."

**"If your students ultimately aren't doing better than you, you haven't done your job."**

—Professor Peter Harmer

**"Mentoring requires ongoing investments of time. It's a commitment I give to students with passion or fire in their bellies."**

—Professor Joyce Millen

From Harmer's point of view, one of the benefits of being a mentor is learning from your mentees. He enjoys talking with Knight about her latest paper or research, and he proudly notes that some of his students, who've gone on to law school or to MD/PhD programs, have "left him in the dust." "If your students ultimately aren't doing better than you, you haven't done your job," he says. "It's nice to be able to say you had a small part in helping someone achieve a goal, find satisfaction in their work or find their place in the world."

### **Mentoring for a Better World**

For anthropology professor Joyce Millen, mentoring students isn't just about helping them find direction in studies and life — it's also an indirect way to make the world a better place.

"Mentoring isn't about one-off meetings here and there; it requires ongoing investments of time. It's a commitment I give to students who show a particular passion or fire in their bellies," she says. "I prefer to work closely with the students who live our Willamette motto, who want to improve the world in some way. Devoting additional time to these students can have positive ripple effects."

One such student is Hania Mariën '17, who first encountered Millen last fall when she took her People and Cultures of Africa class.

Mariën was interested in understanding why children's books in school libraries didn't correspond well with the growing ethnic and cultural diversity of school populations. With Millen's help, she made contact with an expert at Boston University and developed a successful proposal for a Carson Undergraduate Research Grant. Based on her interviews and observations at three local elementary schools, Mariën then wrote a 42-page report, *Barriers to the Use of Multicultural Literature in the Salem-Keizer School District*.

"[While] 37% of the United States' population identifies itself as people of color, only 10% of children's books published in the last 21 years contain multicultural content," she wrote. "This limited diversity in the publishing world creates a variety of real, but maneuverable barriers to using multicultural literature, in and out of the classroom."

Multicultural literature is important not only because it improves reading and learning skills among children of color — it also develops cultural awareness and reflects the reality of our diversifying world. Recent award-winning multicultural books for children include "The Crossover" by Kwame Alexander, which follows two African-American boys who love basketball

and hip-hop, and "I Lived on Butterfly Hill" by Marjorie Agosin about a young girl from Chile sent by her parents to America during the turmoil of the Pinochet era.

Thanks to Millen's connections on local education committees, the Salem-Keizer school district is now interested in using Mariën's report to help increase the number of such books in its school libraries.

"I owe a lot to Professor Millen for getting my report into the right hands, as I couldn't — and probably wouldn't — have pursued this opportunity without her," says Mariën. "My report would probably have just gone into the academic commons. Instead, it's effectuating change."

Good mentors are easy to find at Willamette, Mariën says: "The professors are always really accessible and students feel comfortable going to ask for help. With a mentor it's more than going to ask for help with a project — it's asking for advice about life."

She describes her relationship with Millen as "grounded in mutual respect." "I can go to Professor Millen with just a glimmer of an idea, and come out with better direction for what to do next. Professor Millen showed me that I could turn my ideas into action," she says. "She always asks me what I want to do after graduation. She challenges me to think about my place in the world and what I can do in it."

Millen calls mentoring "the most important thing I do." It allows her to hone in on students' interests and potential and provide personalized advice rather than the one-size-fits-all guidance she can offer in class. Like other faculty mentors, Millen guides and advises students on every step of their research — from design to proposal-writing to implementation to analysis and finally to dissemination of findings.

Many of Millen's students receive Carson Grants, as well as major national awards including Fulbright Grants and Truman Scholarships, because she strongly encourages them to do independent research.

She says, "I push students to be courageous, to get out into the world."

### **From Strangers to Friends**

Last summer, David Nguyen MBA'17 left his home in Ho Chi Minh City, Vietnam, and traveled almost 8,000 miles to the United States — a country he'd never visited before. When he arrived in Salem, where he knew no-one, he felt nervous and uncomfortable.

Yet, within a few months, Nguyen had gained enough confidence to network with local business leaders and set up critical contacts for potential internships. Nguyen, a student in the Atkinson Graduate School of Management's early career and career change MBA program, credits much of the

## **“That’s what mentoring is all about — relationships. It’s an investment in someone else.”**

—Warren Bednarz ’81, MBA’09

## **“Mentoring really affected my life. Now, I’m paying it forward.”**

—Rachel Kittle JD’08

transformation to a stranger who became a friend: Warren Bednarz ’81, MBA’09.

Nguyen and Bednarz met through AGSM’s mentorship program (see sidebar), which pairs MBA students with successful professionals who provide guidance, coaching and network-building.

“As an international student, everything was new to me,” says Nguyen, who trained as a pharmacist and worked in pharmaceutical sales and marketing in Vietnam before coming to Willamette. “And Vietnamese people tend to be shy with strangers. I knew I needed to change, but I didn’t know how. Warren showed me how.”

Despite their different backgrounds, the two men share an interest in entrepreneurship, which is one of the reasons AGSM’s career development staff matched them for the mentorship program. Bednarz owns a real estate investment company, while Nguyen is focusing on marketing and entrepreneurship through his MBA.

Having been through Willamette’s rigorous evening MBA program, Bednarz is able to provide practical advice and much-needed encouragement. He’s also warm and welcoming — one of the reasons why, during his six years in the mentoring program, he’s been paired with international students from countries including Afghanistan, China and Vietnam.

He’s helped them improve their English speaking skills, move into apartments and learn to drive. Bednarz often takes Nguyen to meetings of a local Rotary Club, and he also invited him to his house to experience an American Thanksgiving.

“I enjoy it because it’s not just all business; it’s about developing personal relationships,” says Bednarz, who’s also a Salem city councilor. “That’s what mentoring is all about — relationships. It’s an investment in someone else.”

Years after they return home, some of Bednarz’s students still stay in touch with the mentor who not only helped them

develop professionally but also enabled them to adapt to a new country and culture.

“Even though the program’s not about making lifelong friendships, that’s what often happens. Mentors are invited to students’ weddings and graduations,” says Beth Ursin MBA’00, assistant dean and director of career development at AGSM. “The program creates a really strong bond between people.”

For that reason, Bednarz is passionate about encouraging others to become mentors. “People are afraid because they don’t think they have the knowledge to be a perfect mentor,” he says. “But everyone’s had valuable experiences that they can share with others. Plus, mentoring is a two-way street. None of us has the perfect game — we’re all still learning.”

### **Paying It Forward**

Rachel (Wixson) Kittle JD’08 was so impressed with the mentoring she received while studying at Willamette’s College of Law, she now uses the same approach to help youngsters find their way through school and life.

Last July, Kittle set up a nonprofit called Leadership Launch in Mukilteo, Washington, to help local first-generation or disadvantaged college-bound high school students. The organization — which shares Willamette’s motto, Not unto ourselves alone are we born — aims to provide students with skills to succeed in college and also to become leaders in their communities. Mentoring is an important element of the program because Kittle personally knows the transformations created by such nurturing relationships.

“Mentoring really affected my life,” she says. “Now, I’m paying it forward.”

In 2005, as an overwhelmed first-year law student, Kittle found a lifeline through the college’s mentoring program, which matched her with Concetta Schwesinger JD/MBA’88.

Despite her hectic schedule as the Oregon District Attorneys Association’s liaison to

the state child support program, Schwesinger made time to meet regularly with Kittle. She reassured Kittle that she’d make it through law school, saying “I’ve been through it, and I *know* you can do it.”

She helped Kittle develop a calming mantra to ward off exam nerves, introduced her to other women in the legal field, and eventually helped her land her first job as a family law attorney.

Schwesinger also shared openly and honestly her personal experiences about how a legal career meshes with family life. “Rachel had questions about how to balance career and family life,” she says. “As I’d struggled with achieving that balance, I could provide information and camaraderie.”

In a nomination letter for the law school’s 2006-07 Mentor of the Year Award, which Schwesinger won, Kittle said, “Concetta is a wise teacher and a great friend. I could not have asked for a better mentor to help me through the toughest years of my life.”

Initially, Schwesinger felt nervous when she signed up for the college’s mentoring program. She worried she’d feel uncomfortable with the mentees or, despite her career success, not be able to offer valuable advice. Then she remembered her own difficult journey through law school without the benefit of a formal mentoring program. “I realized I could have used a mentor for information about life and being a lawyer,” she says. “Plus, it’s so important to give back, it’s worth the risk. You just have to get past the fear factor.”

Now that Kittle lives hundreds of miles away, busy with her own family and her nonprofit, she no longer enjoys frequent contact with her mentor. Yet she knows Concetta is always ready to help if needed.

“Mentoring isn’t about an outcome; it’s about the journey. It’s a relationship, which is ongoing and fluid, with ebbs and flows,” Kittle says. “And the relationship endures, even when life changes.” ☐

# Giving Back as a Mentor

## Here are some of the ways Willamette alumni give back by becoming mentors:

Each summer, about 50 first- and second-year MBA students are accepted into the **Atkinson Graduate School of Management's** competitive mentoring program. They are selected from among many candidates based on their application forms and one-on-one interviews that help Beth Ursin MBA'00, assistant dean and director of career development, match them with suitable mentors.

About 50 mentors, many of them Willamette and AGSM alumni, participate in the program, representing businesses,

government agencies and not-for-profit organizations in the Salem and Portland areas. They act as role models and coaches for their mentees, offering an expert perspective on business matters.

Meeting with their mentees at least once a month during the school year, mentors hold the students accountable for achieving their mentorship goals. Typically, mentors invite their students for job-shadowing, to meetings of professional organizations and to networking events — and along the way, lifelong friendships often develop.

At Willamette's **College of Law**, the largest practitioner-student mentee program in Oregon pairs

about 150 first-year students with lawyers and judges who serve as mentors during the students' three years in the college.

As with the AGSM program, many of the law school mentors are Willamette graduates. They help their mentees become familiar with the practice of law by taking them to observe legislative hearings, mediation, settlement conferences, arbitrations and rulemaking proceedings. They may introduce them to judges and justices, explain what it takes to become a partner in a law firm, and offer their insights into hiring trends in the legal job market.

Through their counsel and support, mentors help their

mentees make the transition from law student to legal professional.

Through a collaborative effort by the Willamette University **Alumni Association** and the **Politics Department**, politics students can learn from accomplished politics alumni working in areas such as government, policy, advocacy and communications. Currently, 11 pairs of mentors and mentees connect regularly either in person or virtually throughout the year and at alumni association networking events. The alumni association also hopes to develop similar programs with other academic departments.

## Peer to Peer

Willamette students also carry out important mentoring roles for their peers in initiatives from the **College of Liberal Arts and campus administrative offices, including:**

### College Compass Program

In this first-year experience mentoring program, revised for this fall, student mentors will share their expert insider knowledge to help freshmen transition successfully into the Willamette community. In weekly meetings of groups of about 15 students, the student success mentors will share their wisdom about adjustment to college, both in and outside of the classroom. Topics will include managing your time — and yourself — for success in the first year and after.

### Mosaics Mentoring

The Office of Multicultural Affairs offers the Mosaics mentoring program to support freshmen who are of color, multiracial, biracial or multicultural. Currently, some 55 upperclassmen pair up with freshmen to provide support and friendship to help them deal with

homesickness, loneliness and other issues. The program also organizes retreats, conferences and on-campus events with the aim to “make Willamette begin to feel like home.”

### Community Mentors

Based in Willamette's residence halls, 34 students work as community mentors to facilitate relationships among residents and help build a sense of community. As part-time members of staff for the Office of Housing and Community Life, they live in the residence halls to serve as students' role models and advisors.

### Writing Center

Writing is a major mode for students to learn and to communicate what they've learned. Peer mentors in the Writing Center can help students with projects ranging from a class paper to a senior thesis. In one-on-one, face-to-face meetings, these experienced writing consultants from a variety of disciplines provide friendly, supportive feedback, constructive criticism and technical advice.



**“Mentorship is a real Willamette thing — it’s like seeing the motto in action.”**

— Beth Ursin MBA'00  
assistant dean and director of  
career development at AGSM

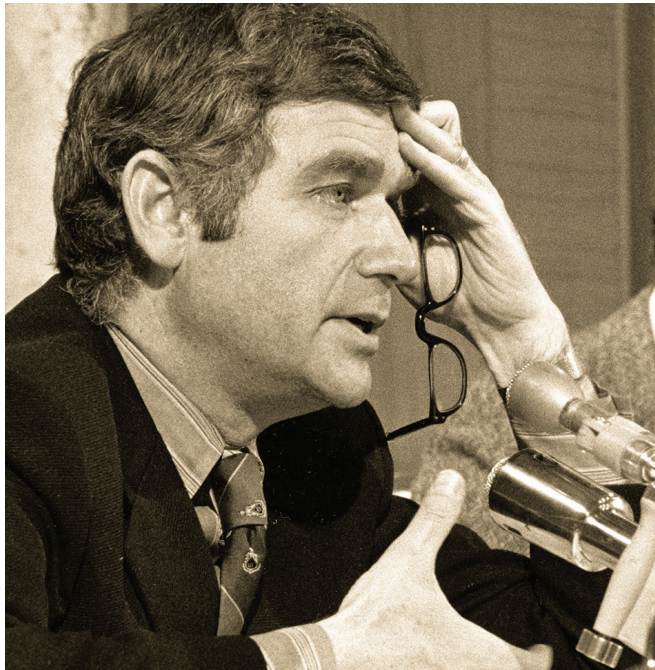

## Exploring a Legacy

From the economy and education to transportation and science, **Sen. Mark Hatfield '43** dedicated his career to bettering the lives of Oregonians. But many people are less aware of the significant impacts he made abroad.

While serving as an Oregon senator from 1967-1997, Hatfield fought for international human rights. He also worked to slow the nuclear arms race, to cut military expenditures and to end the Vietnam War.

On Jan. 26, the History Department, Politics Department and Willamette University Archives and Special

Collections brought a team of Hatfield's former foreign policy advisors to campus to discuss Hatfield's legacy.

For visiting history professor **Christopher Foss '07**, who served as the event's moderator, the roundtable discussion proved Hatfield was a true humanitarian in matters of foreign policy.

"The senator was loved by so many people in so many ways — as a mentor, advisor, a dean of men, a professor, a senator, a governor," he said. "You can't say that about the vast majority of politicians."

## Psychology Professor Wins National Teaching Award

Described as "dynamic," "brilliant" and "supportive" by her students, psychology professor **Courtney Stevens** won the coveted **2015 Jane S. Halonen Teaching Excellence Award**.

Bestowed by the American Psychological Association, the award is given to one early career psychology professor nationally to recognize excellence in psychology teaching.

Stevens has taught at Willamette since 2008. During that time, she has developed and taught seven different

courses across the psychology curriculum. She's also incorporated major service-learning components into three courses.

Humbled by the recognition, Stevens says her primary goal as an educator is to help students develop their self-confidence and critical-thinking skills.

"I put my heart into teaching," she says. "I deeply value the opportunities I have as an educator to work with and inspire students, and I strive to be a good steward of these opportunities."



**"Your La-Z-Boy is more likely to kill you than an Islamic terrorist."**

—Religious scholar Reza Aslan quoting an FBI statistic during his speech, "Holy Wars: Religion and Violence at Home and Abroad," on campus Feb. 9 as part of Willamette's Atkinson Lecture Series.

# 10

The number of years since the Atkinson Graduate School of Management's evening MBA for Professionals program was established. Last fall's 45 students in Salem and Portland was the largest combined class so far.

## The Breakfast Club



**They emerged from the dark recesses of the library into the chilly outdoors, focused on one thing and one thing only. Food.**

Heeding the call of Midnight Breakfast, hundreds of students gathered in Goudy

on Dec. 6 to feast on a free meal of doughnuts, bacon, pancakes and scrambled eggs. Faculty and staff — including **President Steve Thorsett** — serve the breakfast each semester to fuel students for their final exams.

## Run, Rabbit, Run!

**Inspired by Ralphie's pink bunny pajamas in "A Christmas Story," Jake Stout '04 sported a similar look for the Holiday Half Marathon in Portland.**

Finishing the race in 1 hour, 21 minutes and 16 seconds, Stout won an unofficial world record for running the half marathon in an animal costume. An Australian man dressed as a sheep set the last record in 2014.

Stout, who borrowed his outfit from the Portland Trail

Blazers mascot, is no stranger to competing. He ran track and cross country at Willamette and has since participated in several marathons around the country. The full-time physical therapist is also a part-time distance coach at the University of Portland.

Although he became hot and sweaty in the felt suit, Stout says he willed himself to finish what he started.

"Twenty minutes of being uncomfortable was worth a lifetime of glory," he jokes, adding he may don the outfit again for the Willamette Alumni Mile on March 26. "I love that people smile and laugh at the ridiculousness of it all."

Stout's record is unofficial until he files the necessary forms with Guinness World Records and the Guinness officials accept his claim.



# #5

The National Jurist ranked the College of Law fifth in the nation for Best Schools for Small Law, referring to the number of 2014 graduates who found employment at small law firms. Willamette was the only Oregon school included.

## Combating Climate Change on the World Stage

**What do Jane Goodall, John Kerry and Jake Kornack '17 have in common? They each attended the Conference of the Parties climate summit in Paris this past winter.**

As part of an ambassador program by Conergy, a global developer of solar energy projects, Kornack traveled to Paris to report on history in the making.

The conference attracted about 50,000 participants, including heads of state, dignitaries, business leaders and celebrities — all intent on discussing the effects of climate change and the need to curb dependence on fossil fuels.



To learn more about Kornack's experience and the people he met, check out his blog at [bit.ly/kornack](http://bit.ly/kornack).

## Simply the Best

Based on value, academic caliber and student reviews, Niche and MSN both named Willamette the "best" college in Oregon.

What's more, Poets & Quants ranked AGSM's MBA program as top in Oregon, while CEO Magazine listed it as one of two Tier 1 schools in Oregon and one of the few ranked programs in the Pacific Northwest.



# Of Fire Dancers and Fantasy Lands

When Willamette students club together, anything can happen.

By Tina Owen

A cat named Hamlet crouches on the Animal Care Club table, while nearby students in yellow T-shirts advocate earnestly for human rights.

Elsewhere at the Spring Activities Fair, representatives of other student organizations make their case for support. At Willamette, students looking for co-curricular activities — to relax, expand their circles of friends, stretch their minds or bodies, or engage their social conscience — are spoiled for choice.

Some 100 organizations, in categories including academic, Greek, multicultural, performing arts, religious, social and service, cater to every interest. And in the rare instance where the perfect club doesn't exist, students are encouraged to start their own.

One of the oldest organizations, the Philomathean Society (which now sponsors public debates and other opportunities for intellectual enlightenment) can trace its roots back to 1856, when the Oregon Territorial Legislature passed an act incorporating it as a literary society for Willamette teachers, trustees, patrons and students.

Over the years, many student-led activities have come and gone. Even Glee — a long-standing tradition beloved by generations of Willamette students — eventually gave way to changing times and newcomers such as the Digital Art Club and the Institute for Healthcare Improvement.

With so many options, many students belong to several clubs. Here are a few that currently capture the interests — and the passions — of today's Bearcats.

## > Alianza

It aims to educate, to celebrate, to help people broaden their cultural horizons. But just as importantly, the Alianza club provides Latino students with a welcoming home away from home.

"Because the club provides a safe environment for students who identify as Chicanx\* or Latinx\*," says president Marisol Garibay-Cervantes '17, "we have days where we just come together and eat authentic food and feel a little less homesick."

One of 10 multicultural campus organizations, Alianza regularly hosts potlucks, educational sessions and celebrations for ethnic festivals. While the club has about 20 members, it usually draws many more people to its festivals. At a Dia de los Muertos/Day of the Dead event, students and children from the local community proudly donned white face paint depicting skull masks, while performers in vividly colored costumes whirled around in traditional dances.

"We welcome people from all backgrounds who want to learn more about the Latino culture," says Garibay-Cervantes. "Alianza has helped me embrace my roots and made me feel proud to be a Latina."

\* Gender-inclusive terms







### Poi Club

The weighted ropes writhe and blaze, painting luminous patterns on the evening sky over the Quad. In the midst of this flurry of fiery activity, a student stands calm and focused.

Members of the Poi Club soon learn that concentration is paramount in this highly visual performing art derived from traditional Maori culture. Currently, some 20 members meet once a week to play with fire.

To a soundtrack of booming music, they learn how to swing kerosene-doused, flaming staffs, hoops and metal chains close to their bodies. Appropriately, the club's advisor is the assistant director for campus safety — although former club leader Crystal LeFebvre '16 says, "Surprisingly, the most common accidents are due to the heavy metal of the equipment, rather than the fire."

Much of Poi's appeal lies in its exhilarating, adrenaline-driven nature. "The first time you light up, it's terrifying," says LeFebvre. "You can't hear anything other than the fire consuming oxygen."



### Settlers Club

As the ship lands, Aaron Romero '16 jumps ashore and races to stake his claim. If he beats his competitors, he won't just be wealthy — he could be the "King of Catan"!

Since 2008, Willamette aficionados of the internationally best-selling Settlers of Catan board game have schemed, battled and out-strategized each other to acquire land, build roads and assemble armies on the fantasy island. Currently, about 12 regular players meet twice a week in Montag Den to play what club president Romero calls "the best board game in the history of board games — a better, friendlier, less eye-gouging version of Monopoly."

The sessions provide a great antidote to the stresses of studying. Plus, the club has an ambitious long-term game-plan: to build the world's largest Settlers of Catan board. "If we succeed," says Romero, "not only will Willamette have another world record (in addition to the one for the largest Red Light/Green Light game), but we'll be the only club with a world record."



### Campus Cursive

The anonymous notes crop up all over campus, stuffed into a student's mailbox or wedged between the cushions of a sofa in The Bistro.

Wherever they're discovered, the handwritten missives are sure to brighten someone's day, with sentiments like "Hi, Friend — You Rock!" or "I understand what you are going through, but you are a strong person and you can get through it."

Since spring 2014, members of the Campus Cursive Club have spread such messages of love, positivity and friendship. Part of the national More Love Letters organization, the club members provide appreciation and support to people at Willamette, as well as mailing notes to strangers who leave requests on the national website.

"It allows students who may be experiencing hardship or difficult times to know that they are not alone," says club leader Briana Fortnam '16. "Members enjoy writing these letters because it is a really easy, low-commitment and low-pressure way to relieve stress and spread positivity while enjoying the company of other students and getting to know other people."



### WEMS

Every weekend, groups of Willamette students head to the Campus Safety Office — not to report a problem but to help deal with them.

Members of WEMS (Willamette Emergency Medical Services) are on call from Thursday through Sunday night. Founded in 1997 and now supervised by staff from the Bishop Wellness Center, the club is the only collegiate EMS program in the Pacific Northwest. Fully trained and professionally licensed with the State of Oregon as emergency medical technicians or responders, members can deal with issues ranging from rudimentary substance abuse to severe wounds.

While they do see cases of drug and alcohol use, they also tend to injuries such as sprained ankles and broken bones or illnesses such as the flu. It's all good practice for the many club members who are in pre-health programs.

"I love the chance to help others and have the Willamette community, particularly the students, place their trust in us and call us for help when they need it," explains Jameson Hall '17, who says his WEMS experience will help with his plans for a career in law enforcement.

"Perhaps most importantly, WEMS has given me the opportunity to learn how to work closely with others under very stressful circumstances. Whenever the duty phone rings, our adrenaline and blood pressure spike, but when we get together and arrive on scene, we all have confidence in each other. We've been trained and have practiced so many times that everything just flows." □

*Research by Lyra Kuhn '16*



# FULL SAIL AHEAD

**International boat designer Mark Mills '90 has crafted a successful career out of his love for sailing.**

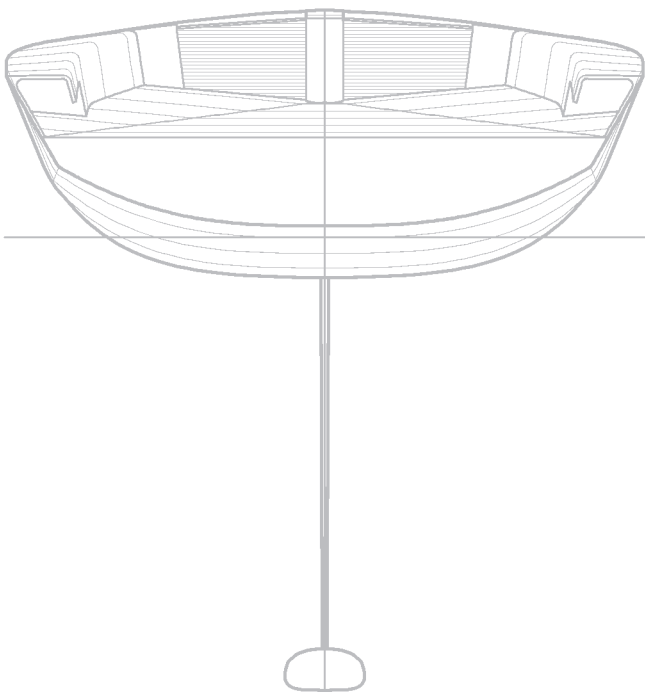

Growing up in Ireland and America, Mark Mills was fascinated with airplanes. As he drew them over and over again, he imagined soaring into the blue sky. Then, he took sailing lessons and succumbed to the lure and challenge of a different kind of blue expanse.

As drawings of planes gave way to sketches of sailboats, Mills began to chart a different course for his life and career. Today, Mills is a highly successful yacht designer based in Ireland, where he took those auspicious sailing lessons.

His company, Mills Design ([mills-design.com](http://mills-design.com)), creates high-performance racing and cruising yachts for clients around the world. Mills has won a raft of honors, such as Seahorse magazine's Sailor of the Month in December 2014, the 2009 Irish Sailor of the Year Award and the Asian Marine and Boating Best Designer Award in 2010 and 2015. His boats regularly win top races as well as Boat of the Year titles.

Apart from the sheer beauty and thrill of sailing and racing, Mills appreciates the mental challenge of designing a boat. "The physics of sailing is quite complex — more so than aircraft flight — as it combines lift and drag equations in two fluids (air and water), as well as the interface effects between them," he explains. "Designing racing yachts is balancing those effects to attempt to approach a theoretical optimum that will be tested in real-world conditions that don't conform to the steady-state computer models — and that have to be sailed by people instead of computers."

During his time at Willamette, despite the university's close proximity to the ocean, Mills yearned for easy and regular access to the water. "I missed the sea and competitive racing," says Mills, who remembers sitting in a Russian class and filling his notebook with

“The **physics of sailing** is quite complex — more so than aircraft flight — as it combines **lift and drag equations** in two fluids (air and water), as well as the **interface effects** between them.”



Mark Mills, center back, joins in the celebration after the yacht he designed, the SuperNikka, won the Maxi Yacht Rolex Cup in 2015 in Porto Cervo, Italy. Photos courtesy of Fabio Taccola.

sketches of boats. For the final project of his art degree, he created a yacht design using computer modeling and airbrush:

After graduation, Mills moved to San Francisco, bought a small boat and spent a year living on it, sailing or racing every day. He'd already worked every summer during college with a boat designer in the Bay Area, so he next embarked on a two-year yacht design course at Southampton Institute in England, learning about naval architecture, pure physics and math, and boat engineering. In his spare time, he raced with some of the best teams in the U.K.

In 1996, Mills launched his business with his first boat, a 31-foot racer cruiser called Aztec. Today, he works for individual clients or boat-building companies, designing boats ranging from leisure cruisers to racing yachts, with price tags spanning from \$125,000 to \$20 million.

Over the years, Mills has seen technology become more critical to cutting-edge boat design. “A decade ago, I drew a generation of very successful boats relying primarily on experience and intuition, and they were engineered and built using 2D drawings,” he says. Now, he works with a team of research and development specialists in engineering and computational fluid dynamics, and each boat undergoes a complicated modeling process.

What hasn't changed is Mills' passion for sailing and competition. “Yacht racing is a very complex but evenly weighted challenge between you, your boat, your competitors and the elements,” he says. “Chess is often used as a comparison, but that may be too purely cerebral. When you're sailing in a stunning venue on a good day, it's hard to beat.”



# 4 TO WATCH



THEY DIDN'T CHOOSE MUSIC; MUSIC CHOSE THEM.  
NOW, THESE FOUR WILLAMETTE MUSIC GRADUATES  
SEEK TO SHARE THEIR TALENTS WITH THE WORLD.



## BRENT HENGEVELD '11

**Where he's been:** After Willamette, Hengeveld earned a graduate certificate in Scoring for Motion Pictures and Television from the USC Thornton School of Music. He now works as a multimedia composer in Los Angeles. "It's freelancing, in all its glory and horror," he says.

**What he's learned:** Music called to Hengeveld for as long as he can remember, so turning his passion into a job was an easy decision — and a difficult one. "This career is not easy when you start, and especially when it's your first career," he says.

**Where he's going:** In addition to writing music for video games, Hengeveld is scoring his first film — an independent holiday picture set for release later this year. Explaining the appeal of his craft, he says, "In a world that I still struggle to make sense of, music has always called to me. The beauty is that different people will find different meanings in music, none of them invalid."



Photo: Amanda Tibotin

## CHLOE PRENDERGAST '14

**Where she's been:** At Willamette, Prendergast was one of a select few students allowed to play the famed Waller violin. Likely crafted in the 1600s, the Italian instrument was discovered hidden beneath floorboards during a renovation of Waller Hall in 1988.

**What she's learned:** Although the Baroque period spanned from 1600 to 1750, Prendergast says its music is timeless. "The musicians were portraying the same emotions we experience today," she says. "It's relevant. It brings history into the present."

**Where she's going:** Prendergast is a graduate student in Baroque violin performance at the University of Washington. After she graduates, she aspires to travel and perform with other Baroque musicians. "Music doesn't make any sense without someone there to listen to it," she says. "I can't imagine doing anything else."



## PHIL TAYLOR '11

**Where he's been:** Taylor has won not one, but two Broadcast Music Inc. (BMI) Student Composer Awards — the first in 2009 and the second in 2014 for his orchestral work "Chiaroscuro."

**What he's learned:** What Taylor enjoys most is collaborating with stellar artists to make his compositions come alive. "Nothing compares to the way I feel when I've worked closely with someone to make music that fits them like a glove," he says. "It's an amazing journey often capped with an unforgettable performance."

**Where he's going:** A PhD candidate at the University of Chicago, Taylor is writing his dissertation work — a concerto for harp and ensemble. "Composing is a very intimate task," he says. "It's also a complex, outgoing social dialogue, involving both the musicians who play my work (and often inspire it, too) and their interaction with the audience."



## MATT SAZIMA '14

**Where he's been:** For the last two years, DownBeat magazine — a publication that honors student talent around the globe — has recognized the caliber of Sazima's arrangements through group awards and the Best Jazz Arrangement award in 2014.

**What he's learned:** Strongly influenced by his Willamette music professors — Wallace Long, Mike Nord and James Miley — Sazima hopes to one day inspire young musicians in a similar way. He says, "They set an example through their amazing work ethic and their commitment to provide opportunity and support for their students."

**Where he's going:** Sazima is completing his master's program at the California Institute of the Arts in Valencia, writing for ensembles and practicing piano, vibes and voice. His long-term goal is to record his music and work as a tenured professor.

Hear these alumni demonstrate their musical skills at [willamette.edu/go/musicians](http://willamette.edu/go/musicians).

**In 1894, a group of Willamette faculty and students journeyed several days by wagon from campus to visit Mount Hood.** According to a Collegian article detailing the expedition, the travelers aimed to “experience the sensation of sleeping in a forest, under the open sky, like a true child of nature.”

More than a century later, a new batch of intrepid explorers drove a couple of hours east of campus in a van — and the rain — to hike the forest trails of Opal Creek Wilderness and Scenic Recreation Area. The trip was organized by the university’s student-run Outdoor Program, now celebrating its 10th year of helping Bearcats discover the thrills of activities such as kayaking, camping, horse-riding and rock climbing.

Generations of Willamette students come and go, but the timeless beauty of the Pacific Northwest endures — and beckons.

## 1894



## 2015







# CHANGEMAKERS

As sexism in video gaming and tech gains notoriety, three Willanette alumni are working to transform the industries.

By Sarah Evans

When **Jennifer Allaway '15** posted an online survey asking people working in video gaming to answer questions about sexism in the industry, anonymous harassers bombarded her survey with fake data. Some threatened her with sexual assault and urged her to commit suicide.

**Janice Levenhagen-Seeley MBA'10** says she lost out on jobs at two major tech companies when the employers learned she was pregnant, with one saying that maternity leave would be inconvenient for the company.

**Elizabeth Swensen '08** started playing video games in elementary school, but she didn't consider the possibility of pursuing a career in that industry until she was in her early 20s. Games and a gaming culture dominated by men made her believe there wasn't a place for her in that realm.

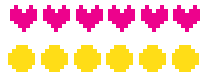

These women's stories exemplify an issue that countless people working in gaming and tech say is a major problem: a "boys' club" culture that, at its least, discourages talented women from entering the industry and, at its worst, discriminates against them and bullies them to leave the field.

"When I see women who are not being treated equally or who are being attacked just because they're women, I get angry," says Levenhagen-Seeley, who now runs a nonprofit that organizes programs and events for girls and women of all ages to encourage them to go into and stay in tech. "It makes you feel like you're not allowed to have a voice. It doesn't even have to happen to you — just knowing that it's happened to others makes you not want to speak out."

The video game industry is admittedly not diverse — a 2015 International Game Developers Association survey of nearly 3,000 people in the industry found that the average employee is male (74 percent), white (83 percent) and heterosexual (80 percent). The same is true of tech in general: the nonprofit National Center for Women & Information Technology reports that women only held 26 percent of professional computing jobs in the U.S. in 2014, compared with 59 percent of all professional jobs.

Concerns about lack of diversity — and whether that leads to an exclusionary culture — are by no means limited to the video game and tech industries. But the bullying of women in gaming gained widespread scrutiny during the last two years due to an extremely vocal and aggressive group of anonymous online harassers who rallied under a Twitter hashtag: #Gamergate.

Arguing that gaming journalism has become too feminist and thus alienated many traditional gamers, "Gamergaters" most notably have launched harassment campaigns against women game developers and critics who speak out about the need for more diversity in the industry and in games (like what happened to Allaway). The harassers' methods sometimes include doxing (broadcasting personally identifiable info about someone on the Internet) and threats of rape or death. When the victims speak out, they're often met with even more attacks — harassers frequently say that women are blowing things out of proportion or that they should "get over it."

The harassment has been serious enough that some women have left their homes and gone into hiding, and after a feminist blogger cancelled a speaking appearance at Utah State University due to someone threatening a shooting at the event, the FBI began

an investigation. The leaders of the Entertainment Software Association (ESA) and major game companies Electronic Arts and Sony Computer Entertainment are among those who have condemned the Gamergate harassment.

At its heart, much of the rhetoric on both sides surrounds the idea of who "belongs" in gaming, and what games should look like as a result. Along with decrying sexism in the industry, more gaming critics are questioning the traditional white male heroes that have dominated most high-budget games until recently — and the fact that, if women appeared in those games at all, they usually were sexually objectified or followed common tropes such as "helpless damsel in distress." It's become more of an issue recently because, while the faces of those who make the games are not diverse, the same is no longer true of those who play.

American consumers spent a whopping \$22.41 billion on the video game industry in 2014, according to the ESA, and 155 million people in the U.S. play video games. And they're not just young

males — 44 percent of game players are women, and the average player is 35 years old (among women, that average goes up to 43). Twenty-seven percent of game players are age 50 or older.

Such changing demographics are slowly opening more doors for women like Allaway, Levenhagen-Seeley and Swensen, who are

carving out successful careers despite what they encountered early on.

Allaway, now studying for her master's in game design at New York University, presented her research on sexism in the industry at several of the nation's largest gaming conferences when she was still an undergrad at Willamette. Levenhagen-Seeley launched her nonprofit, ChickTech, in Portland in early 2012 and expanded to ten chapters nationwide (with two more in the works) in just four years. Also in 2012, Swensen — now a game designer and researcher at the University of Southern California's Game Innovation Lab — earned a place on Forbes' Top 30 under 30 in Entertainment list, in part for her development of an innovative game where players manipulate language in a storybook to shape the female protagonist's path through the story.

Whether they research and speak out against sexism, develop programs to support women, or make games that defy the norm, these women are working to change the tech and gaming industries and their historically male-dominated cultures.

"The more we become complacent about sexist and harassing behavior, the more women and the more talent we drive away from the industry because people are afraid of the culture that we have

Harassers frequently say that women are blowing things out of proportion or that they should "get over it."

created,” Allaway says. “And rather than holding ourselves accountable for that culture and trying to fix it, we’re too focused on blaming the victims for standing up. And that’s what makes me the saddest.”

## Three Women, Three Paths



Allaway can’t remember a time when she didn’t have a video game controller in her hand. One of her baby photos shows her climbing atop her older brother as he plays with his Super Nintendo console. Her family nicknamed her “Goomba” after the sentient mushrooms in the Mario games.

“Video games were how I bonded with my siblings,” says Allaway, who grew up in the San Francisco Bay Area. “By the time my brother was a teenager, he had decided that he was going to

make games for a living, and I remember saying, ‘I wanna make games, too,’ but it was in the same sense you might say, ‘I wanna be an ice cream truck driver.’ When you’re that young, you don’t really understand what it means.”

After her older siblings graduated high school and moved out, Allaway says she “floundered with career ideas.” When choosing a college, she picked Willamette for its strong archaeology program, although she eventually declared a sociology major to explore her interest in gender studies.

In 2013, Allaway’s brother got a job at a major game company, and she longed to join him. At about the same time, the issue of sexism in video gaming was already becoming a hot topic — and Allaway recognized that it would be a prime subject for her sociology thesis. A Willamette faculty mentor instead pushed her to apply for a Carson Undergraduate Research Grant. She won the grant and used it to interview several dozen people and survey hundreds of others working in the game industry about sexism and harassment they had experienced or observed happen to others.

“In many ways, my research was an act of survival,” she says. “I want to work in games, and if we don’t express these views [about sexism in the industry], then this is going to stay in place, and it will continue for a long time.”



Swensen also came from the Bay Area and started playing games at a young age, but not because of familial influence. In fact, her parents initially refused to buy a game console for the house because “they were a little skeptical of video games,” she says. When she was nine, she saved up her allowance to buy her own handheld device. “After I proved I could play games and still keep up my grades,” she says, “it became a big part of my life.”

Swensen never considered that the games she enjoyed might lead to a career, partly because many of the games were geared toward men. The first time her dad tried to buy her a game, in the late 1990s, he walked into a GameStop store and asked the clerk to

recommend something for his daughter. The clerk handed him “Tomb Raider,” which had a female protagonist — but one clad in very short shorts and a tight shirt that highlighted her extremely large chest.

“I didn’t really understand there was a place for me in the game industry when I was growing up,” Swensen says. “[That] delayed my pursuit of something that I now like doing.”

Swensen majored in classical studies at Willamette to indulge her love for stories, particularly those relating to ancient cultures. Although she continued with her video game habit during college, she still never considered following that passion professionally until she neared graduation.

A pivotal conversation with a friend who suggested she consider studying digital media in graduate school inspired her to apply to USC’s MFA in interactive media program. When she got in, she made the leap to study what previously had been only her hobby.

“There was a bit of imposter syndrome at first because I hadn’t grown up studying computer science,” she says, referring to a psychological reaction where people believe they are frauds and don’t deserve the success they have achieved. “But overall, I felt immense relief to finally be around what felt like my people. I felt an amazing sense of belonging. ... I know that sexism is a reality for many in the industry, but I’ve been fortunate to only experience a welcoming culture.”

Levenhagen-Seeley also credits an offhanded conversation with inspiring her to try tech. Her grandmother, noting that Levenhagen-Seeley excelled at high school math and science, suggested that she study engineering in college — a path she had never considered previously.

Taking the advice, Levenhagen-Seeley headed off to Oregon State University to study computer engineering. Unlike Swensen, she did not feel welcomed. “Every time I’d walk into a classroom, everyone would turn around and stare because I was one of only two or three girls there,” she says. “I remember people acting like I was a nuisance because I was social and I talked to them. Every time you get shut down, you withdraw and become more unsure.”

The atmosphere didn’t change when she applied for her first tech jobs. “I had imposter syndrome pretty badly,” she says. “The idea of doing interviews in technology was so stressful that I’d have panic attacks.”

When Levenhagen-Seeley encountered discrimination about her pregnancy during her interviews at two companies, she says it was “the final straw.” She left tech and enrolled in Willamette’s MBA program, thinking she could find a more welcoming environment in a business career (sadly, this didn’t end up being the case at her first post-MBA job; she says she was sexually harassed and then retaliated against after she reported it).

Her experiences later inspired her to launch ChickTech, which started as a hands-on program where high school girls could create tech projects — from robots to phone apps to video games to websites — while learning about potential careers in tech. Today, it also includes a networking and professional development program for women already in the industry.

“Everything that we do at ChickTech has some root in my experiences,” she says. “In high school, I was a girl who had the





potential to be good at technology, but nobody ever thought to get me involved in it. ... Those are the girls we are targeting with ChickTech. We're looking for untapped potential, because there are so many girls who do not identify with the techie stereotype. We try to create an inclusive, empowering and welcome environment."

## What Women Face

"Inclusive" and "welcoming" were not words Allaway heard much when she conducted her Carson research on sexism in the video game industry.

Of the 29 women she interviewed, 23 had experienced sexism to some degree within the industry. In her accompanying online survey of 344 industry employees, 60 percent of women said they had experienced sexism or harassment. Additionally, 77 percent of women and 55 percent of men said they knew women in the industry who had experienced sexism.

The stories she heard from her women subjects were disheartening. One woman told of being promised a job at a prominent game company, only to be passed over for a man — she says the creative director told her it was "kind of a waste" to give her a full-time position because she was probably "gonna end up having kids in a few years and leave anyway." One subject said that when she protested about being paid half what the male designers were for

doing the same amount of work, she was told, "We just can't afford to pay you more." Another interviewee who worked in marketing at a major company described frequently being treated like a "booth babe" (an attractive woman hired by a game company to garner attention for its booth) at a major gaming conference, despite the fact that she "wasn't wearing anything particularly scanty."

One woman summed it up this way: "At some point you just become, well ... numb to it, because it's the same thing every week. ... It's also the numbness of 'I can do nothing, I feel totally powerless.'"

In March 2014, Allaway published an article about her findings on Gamasutra, a prominent video game news website. At around the same time, she had the honor of presenting her work at the Game Developers Conference (GDC), the largest annual gathering of developers. Later that year, she also presented as part of a panel at PAX Prime, one of the biggest conferences for game players.

The widespread positive response inspired her to keep researching. She set up a new online survey for game developers, asking about diversity in game content — and that's when she ran headfirst into Gamergate. After she'd already collected about 700 legitimate responses, she received an anonymous email warning that she was about to be "vote brigaded," meaning people planned to ruin her study by submitting false data. Sure enough, Gamergaters entered 400 false responses, many racist and misogynist, and some including rape and death threats.

## Video Games that Defy the Norm

Many major video games still rely on white male protagonists, but there have been several notable exceptions — and the landscape is changing. Jen Allaway and Elizabeth Swensen recommend several high-budget games from major publishing companies (known in the industry as AAA games) that provide alternate portrayals of women and people of color.

### Beyond Good & Evil (2003)

The heroine of this action-adventure game is Jade, an investigative reporter and martial artist working to reveal a planet-wide alien conspiracy. "Jade was one of the first female game characters who inspired me when I was growing up," Swensen says. "Jade is active, practical, brave and compassionate. Despite the spectacular circumstance, she felt grounded in a way I was not used to seeing in games."

### Mirror's Edge (2008)

This action-adventure game set in a futuristic dystopian society features an Asian woman protagonist named Faith, part of a network of "runners" who transmit messages while evading government surveillance. "Faith is not sexualized," Allaway says. "She is an attractive female of color who is empowering and strong."

### Remember Me (2013)

At the beginning of this game, the woman protagonist, Nilin, has been stripped of almost all her memories by a mega-corporation. Working for an underground resistance group, she goes on a hunt to bring down the corporation and recover her memories. "She can go into people's minds and mess up their memories," Allaway says. "It's a really interesting game, very 'Matrix'-like."

### The Last of Us: Left Behind (2014)

This action-adventure survival horror game features Ellie, a young girl spending time with her friend Riley in a zombie-filled, post-apocalyptic world. At one point, the girls share a kiss that some critics called "a breakthrough moment" for video games. "This is a good example of a well-realized female character in a AAA game," Swensen says.

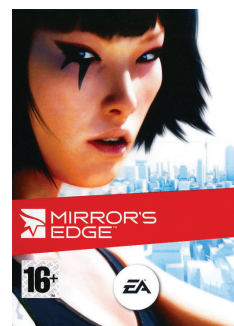

### Recommended Indie Games:

- Thomas Was Alone (2012)
- Gone Home (2013)
- Papo & Yo (2012)

# High Scores

Source: Entertainment Software Association, 2015

“Video games are ingrained in our culture.”

—Michael D. Gallagher, president and CEO, Entertainment Software Association



26% under 18  
30% 18-35  
17% 36-49  
27% 50+

The average game player is

35 years old



56% male  
44% female

42% of Americans play video games regularly (3 hours or more per week)

155 million Americans play video games

Allaway was lucky — although she had to secure her online accounts to protect them from possible cyber attacks, contact police and warn her family, she never received any other harassment. She used the data from the attack to write another article arguing that, by academic definition, Gamergate classified as a hate group. The article, published on the widely read feminist blog Jezebel, earned her even more interview invitations.

Throughout all of her publishing and presenting, Allaway continually heard from other women in the industry who shared stories of experiencing sexism — and they often thanked her for raising the issue.

“There was a really big dearth of dialogue about this issue — it was like a wound that was leaking but wasn’t being attended to,” she says. “Then people started opening it and everything came out. Now we know we have this problem, and people are having a larger conversation [about it]. That’s progress.”

Still, Allaway says the industry has a long way to go to solve the issue. Even though many of the high-profile Gamergate attacks happened a year ago, Allaway notes that the controversy still continues — as evidenced by the hoopla surrounding this spring’s South by Southwest festival in Austin (organizers canceled several panels relating to harassment in gaming after receiving threats of violence; later, they announced a day-long summit on harassment).

“We need to show people that this is still happening with women and people of color and transgendered people in the industry

— they are still being harassed every day,” Allaway says. “It’s important that the industry take it seriously.”

## Change from Within

As more women speak out, the industry seems to be listening.

Peter Moore, the chief operating officer of Electronic Arts — one of the world’s largest video game publishers — told Fortune magazine in September that “if there’s any benefit to Gamergate, whatever Gamergate is, I think it just makes us think twice at times. ... We all need to step back sometimes and think about the environments we create for our people ... and equally importantly how you bring new blood into the company. It can’t all be white males.”

In January 2015, Intel — which at one point temporarily withdrew its ads from Gamasutra in response to an email campaign it did not realize originated from Gamergaters — announced a \$300 million Diversity in Technology Initiative to help increase representation of minorities and women at its company and in the tech industry in general. Several of its investments specifically support women in gaming, including a new scholarship to send promising young women to GDC — Allaway was one of the first recipients.

Numerous programs are popping up nationwide that, like ChickTech, work to encourage and empower high school girls to enter the fields of computer programming and tech — Google’s Made with Code initiative is another example.

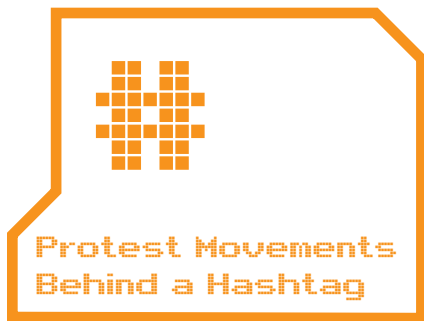

Public speeches and sit-ins are longtime mainstays of protest movements — but today's activists can now add social media to their message arsenal.

The proliferation of social movements online — with followers rallying behind hashtags on Twitter or other social sites — is transforming the way these movements mobilize, says Matthew deTar, a visiting assistant professor in

Willamette's Civic Communication and Media department. Think #BlackLivesMatter, campaigning against violence toward black people, or #Anonymous, a "hacktivist" group that spreads its political messages by organizing cyber attacks against agencies and organizations.

Those are just two of the movements deTar's students examine during his course, "Social Movements in an Age of Leaderless Protest: Ferguson, Occupy, and Beyond."

While he hasn't taught about Gamergate specifically, deTar says the controversial movement fits the mold in many ways — it has no identified leaders, and participants use social media to organize and to spread their cause.

Social media allows such movements to mobilize much faster than in the past, deTar says. Anyone can use a hashtag and have his or her views publicized far and wide. As a result, what once were internal disagreements within a social movement now play out online in a very public way, deTar says.

"With something like Anonymous, for example, you have people who are heavily invested in the tech side of what they do, and then you have people heavily invest in the political side, and those two don't necessarily cross over," he says. "But both of them are following along with the conversation."

And, because of the way social media sites work, opposing sides in a movement typically are not engaging in meaningful dialogue online, deTar says.

"On a Facebook feed, you mostly see only things related to what you have clicked on," he says. "You're curating for yourself a particular type of news feed, and you are unknowingly hearing only one side of the story. The same is true on Twitter, where you follow people and like certain kinds of tweets. You start to understand only one side of a story and get really invested in that side.

"The Internet is doing what it's supposed to do, which is enable everyone, but it also allows for a lot of polarization and anonymous posting, which can be destructive, too."

In the case of Gamergate, the movement has thrived both on Twitter and on sites like 4chan and 8chan, which consist of anonymous message boards.

"Gamergate is particularly powerful because it brings up the invisibility of gender that operates powerfully on the Internet, which is a presumed white male space," deTar says. "A lot of movements today are bringing this up, and saying, 'This is not a white male space, so stop acting like it is.' That's a hard thing for some people to recognize."

Levenhagen-Seeley says one of her goals with ChickTech is to show young girls that their teachers and other role models believe in their potential to be good at tech — and that they are welcome in the industry. It's a critical step toward putting them on the tech path, as a 2014 Google-led study showed that encouragement from adults and peers is the number one contributor to a girl's decision to pursue computer science.

Women like Allaway and Swensen see their role in the industry as one of changing by doing.

After some of her early narrative-based games were honored and exhibited at the IndieCade and Games for Change independent gaming festivals, Swensen was hired at USC's Game Innovation Lab as a researcher and instructor. She now primarily creates educational games that use gameplay as a way to teach strategy and metacognitive skills that are important for making decisions in real life. One such game, called "Mission: Admission," focuses on the strategy of being a good college applicant.

"Our lab is about pushing the boundaries of what games can be," she says. "We ask questions like, 'Can we make a game that helps people get into college, or inspires their career ambitions in science and math?'"

"I'm glad to see the independent directions that many games are taking," she adds. "They're doing things that people haven't heard of or wouldn't expect from the medium. ... I'm very positive about the future. I think the tech industry in 20 years will look a lot different, and I think we'll all be better for it."

Last summer, before starting at NYU, Allaway managed to snag a short-term job working on the narrative for a video game — with a female protagonist — at Wadjet Eye Games, an acclaimed independent adventure game company. She also collaborated on a small text adventure game that featured a lesbian couple, one of them serving in the military in Iraq during the "Don't Ask, Don't Tell" era.

"We've got to push forward with solutions like focusing on getting more women and marginalized people into the industry, and making games that aren't just focused on stories about white guys," Allaway says.

"I'm an artist at heart, and the way I can make change is by creating things that will impact others. I'm trying to design for the future I want." ☒

**What are your thoughts on sexism in video gaming and tech? We want to hear your perspective.**  
Email us at [magazine@willamette.edu](mailto:magazine@willamette.edu).

# ON LOCATION

In a basement lab of Collins Science Center, physics professor Michaela Kleinert and her students work with the building blocks of matter.

Using laser beams and magnetic fields, they trap rubidium and calcium atoms in a stainless steel vacuum chamber. The atoms, which usually whiz around at speeds of several thousand miles an hour, slow to a crawl as they get stuck in what Kleinert calls “optical molasses.”

As they manipulate the atoms in the ultracold temperatures of the vacuum chamber, students aim to combine them and form a new molecule with rare magnetic properties. Eventually, the molecule could play a role in the development of high-speed quantum computers.

For now, this state-of-the-art experiment in atomic/molecular physics and optics provides Willamette students with essential lab skills, fundamental knowledge — and a glimpse into the marvels of the universe.

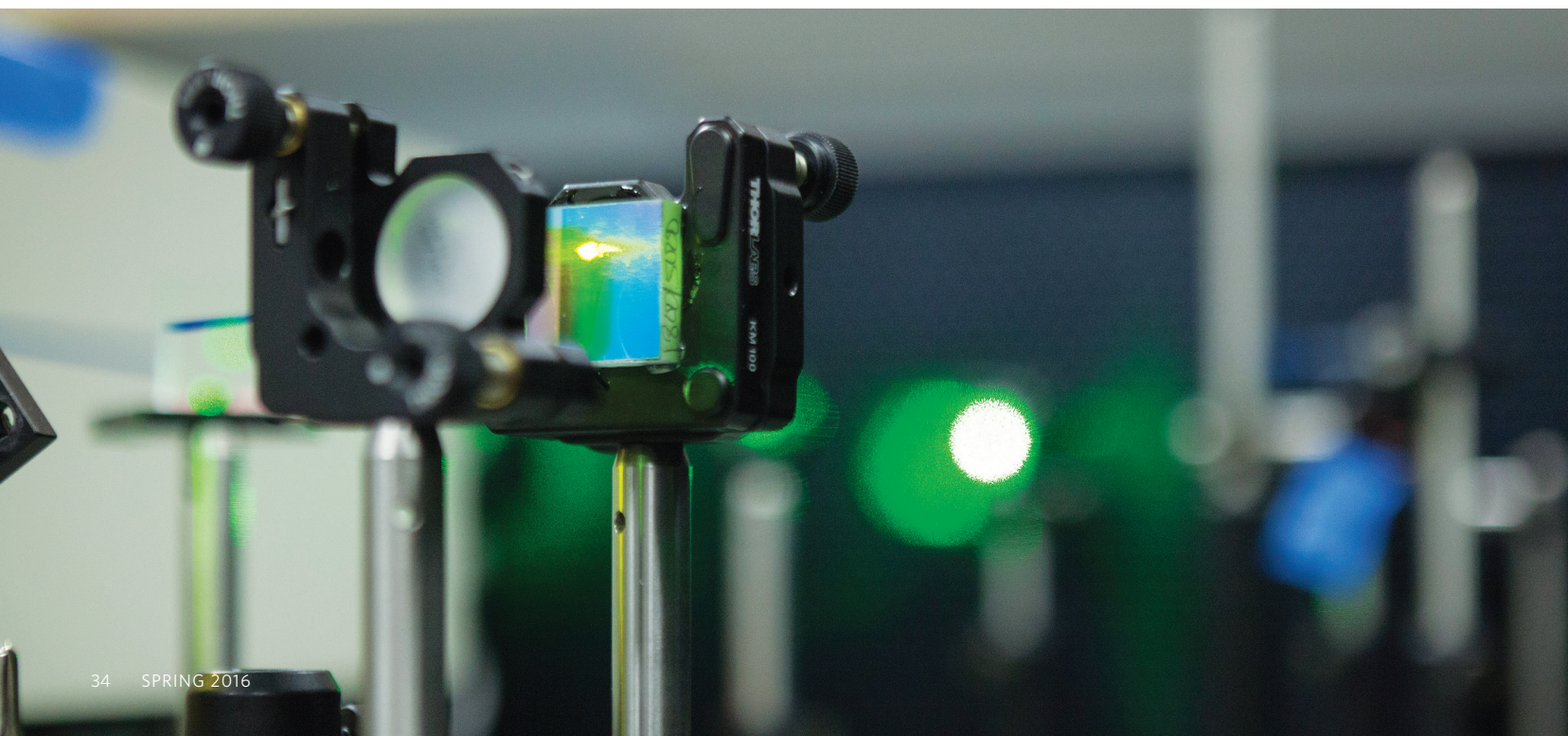
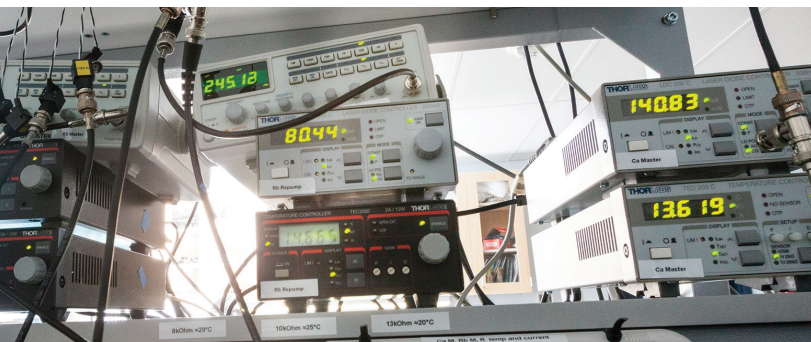
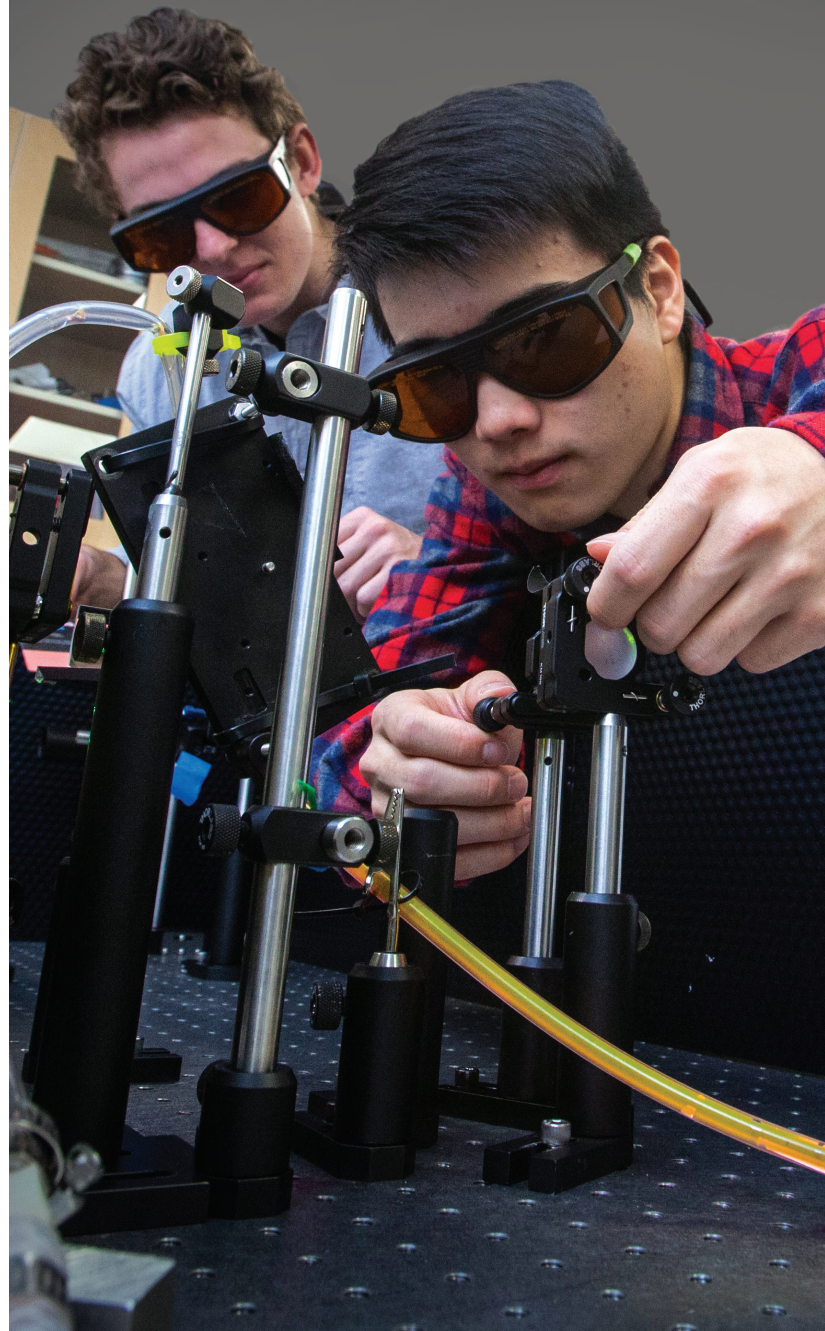

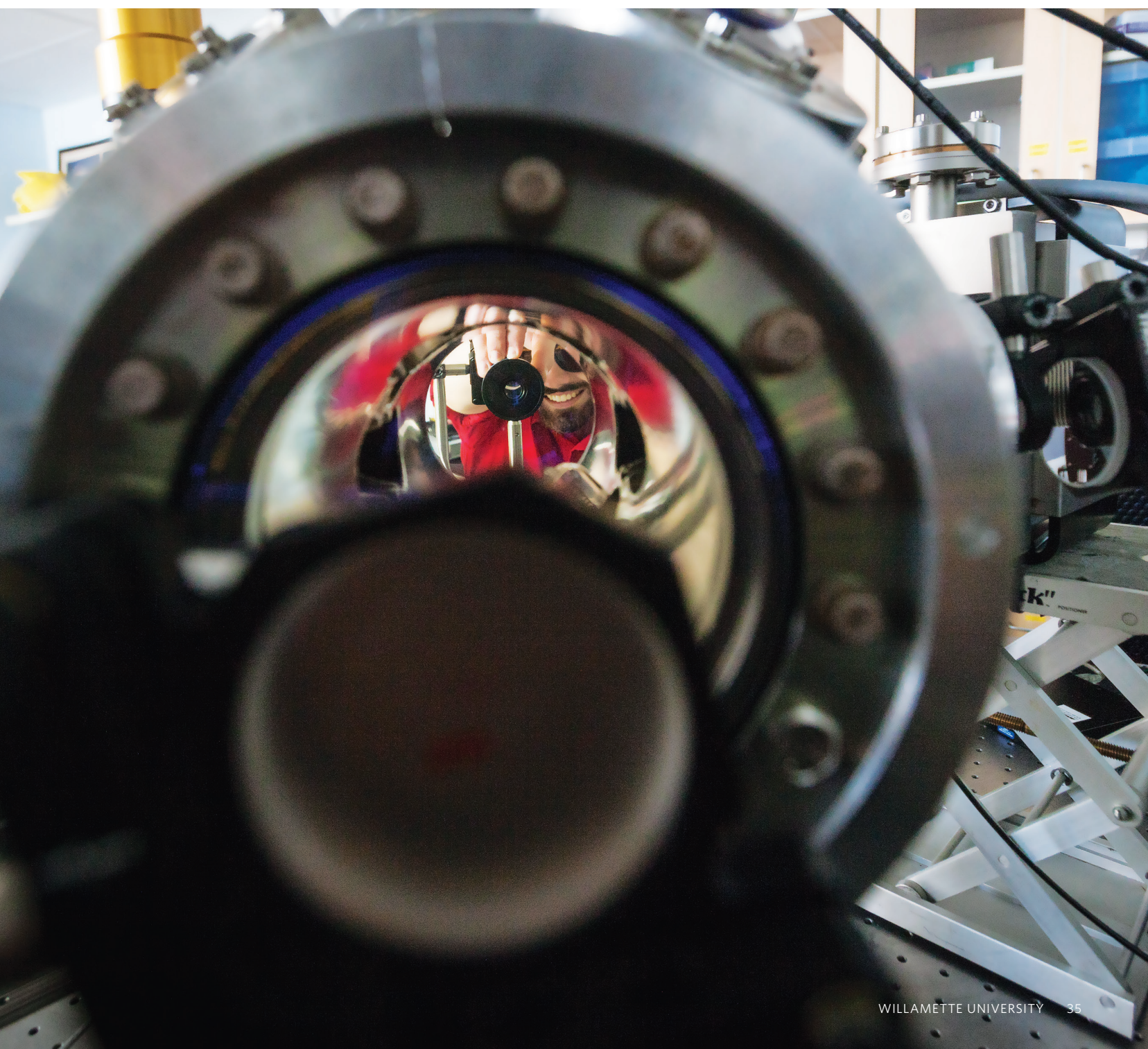

# Cardinal



**Sam Wexman '16 and  
Aaron Schechter '19  
gear up for the 2016  
spring tennis season**

**Kiley Lin '19 sets a  
school record in the  
women's 100-yard  
backstroke at the  
Northwest Invitational**

# & Gold



**Bearcats place second at the NWC Fall Classic in men's golf**

**Women's basketball goes 8-1 in non-conference games**



## A Team Built on a Lasting Foundation

**The Willamette men's basketball team sits around a television in Sparks Athletic Center, intently watching a video. They don't see a replay of a game or a recent practice. What's on the screen is much more important.**

The players are watching a documentary about date rape.

For Head Basketball Coach Kip Ioane '01, MAT '02, sharing the clip with his players is difficult but necessary. As a husband and father, he wants to do everything in his power to stop gender violence.

"I feel this is as much a part of my job as basketball," says Ioane about his four-year character-development program. "We're going past baskets. We're going into real life."

Ioane's basketball program sets out to develop men of character, create a family and build a legacy — in that order. He recruits players with that promise, which is why no one protested when the coach added the educational component in 2013. Monthly readings, movies and quizzes on sexual violence and similar topics became part of the routine.

The players list things they can do to prevent gender violence — such as attend

rallies and support the work of campus-based women's shelters. They read chapters from "Macho Paradox" by Jackson Katz, which explains why violence against women is a men's issue. They role-play how to intervene in potentially dangerous situations.

Bridger Harlington '16, a senior wing, was at first taken aback by Ioane's fervor for the material. Now, he says, "Athletes are role models, whether we like it or not. Stopping sexual violence is on all of us. We all share the responsibility."

When he teaches his curriculum to freshmen, Ioane bombards them with statistics: Nearly all rape suspects are male, most female victims know their assailants, and most perpetrators are repeat offenders.

Such facts — provided by educational materials and local experts — succeed in grabbing the players' attention.

"They don't want these statistics associated with their name, their family's name or our program," Ioane says. "Once I shock them, we can move forward."

Having collaborated with Ioane for the past year, Director of Community Education Carli Rohner says his drive is her "professional dream."

### **Kip Ioane**

**In his seventh season as head coach**

**Previously served eight years as assistant head coach**

**Director since 2009 of the Pro Hoop summer camp for youth aged 7-17**

She's particularly struck by how he tests assignments himself before issuing them to his players. He flew back to his old high school in Montana to give a presentation on the subject and get a better sense of what resonated with youths. Now, as their capstone project, his players make similar presentations either at their alma maters or at Salem high schools.

"He walks the walk," Rohner says. "Kip motivates his players to become better people."

If they utter profane or homophobic slurs, Ioane sentences his men to pushups and laps across Willamette's 12th Street sky bridge. And if they don't complete their class assignments, they're not allowed on the court.

These lessons hit home. Harlington now watches his language and talks to his peers about the dangers of making stupid mistakes while drinking. He also pays more attention



to how the media portrays acts of violence against women.

“You never hear, ‘A man raped a woman,’” he says. “You hear, ‘A woman was raped.’”

Until she met Ioane, Rohner hadn’t heard of any coach, anywhere, who had developed a long-lasting, multiyear character-development program. At Willamette, Ioane’s efforts have created a ripple effect. Other coaches now give similar reading assignments, and some encourage their players to attend Ioane’s classes.

Rohner says the program works because the players can see themselves in their coach. He’s young. He played basketball while a student at Willamette. And he was a finalist for the Jostens Trophy — awarded to the NCAA Division III men’s basketball player of the year.

If these are the reasons his men listen, Ioane isn’t complaining. Having had strong male role models throughout his own life, he now aspires to provide a positive influence for his team.

As he says, “We want to create a place where truth exists between [us], even though we may not want to hear some of it.” ☐

## NEWS & NOTES



### ☑ Cross Country Teams Finish Strong at NCAA Championships

Just a couple of seconds stood between **Olivia Mancl '17** and a national title.

Competing at the 2015 NCAA Cross Country Championships, Mancl placed second in the women’s race — only 2.3 seconds behind the winner. Both Mancl and **Taylor Ostrander '16**, who placed 26th, earned All-America status. Overall, the women’s team placed 10th to claim its third consecutive top-15 finish.

Also at the championships, held in November at Winneconne, Wisconsin, the men’s team placed 28th, with top runner **Nathan Conrad '16** finishing 127th.

Both teams were in fine form at the earlier Northwest Conference championships. The men won the team title for the fourth year in a row, with Conrad finishing third. Conrad, **Yonny Castillo '16**, **Jacob Shafi '16** and **Patrick Loftus '18** were named First Team All-NWC. The women placed second, with Mancl, who won the individual title, and Ostrander, who came in second, qualifying for First Team All-NWC honors.

At the NCAA West Regional Championships, the women claimed first place while the men took third.

Head coach Matt McGuirk also brought home his share of honors, being named NWC Men’s Cross Country Coach of the Year for the 11th time and West Region Women’s Cross Country Coach of the Year for the sixth time.



### Bearcats Hold Second in NWC All-Sports Standings

After the fall season, Willamette is in second place in the Northwest Conference standings for the 2015-16 McIlroy-Lewis All-Sports Trophy.

The Bearcats hold second place on the strength of an NWC title in men’s cross country, second place in women’s cross country, and third place in women’s soccer and volleyball.

The award is named after John Lewis, who worked at Willamette as a baseball coach (1947-72), basketball coach (1947-67) and athletics director (1952-72), and Jane McIlroy, Linfield College’s women’s athletic director, physical education professor and multisport coach. The trophy will be presented at the conclusion of the NWC athletic year in May.



### ☑ Fincher Chosen NWC Volleyball Player of the Year

Outside hitter **Sarah Fincher '16** was selected as the 2015 Northwest Conference Volleyball Player of the Year in voting by the NWC head coaches. In addition, Fincher and **Lindsey Compton '16** were chosen First Team All-NWC.

Fincher led the NWC with 333 kills, was second with 3.54 kills per set and was fifth with a .239 hitting percentage. She registered a season-high 21 kills in Willamette’s 3-2 win against NWC champion Whitworth University on Nov. 6.

During Fincher’s three seasons with the Bearcats (after transferring from Southwest Baptist University), she accumulated 952 kills with a .209 hitting percentage.



## Well Read

*As part of the Mark O. Hatfield Library's latest WU Reads campus-wide campaign, several faculty and staff showcased their favorite books. Here, a few of them reveal the stories behind their choices.*

### The Art of Racing in the Rain

by Garth Stein

Physics professor **Michaela Kleinert** is a self-described “dog person,” which prompted her book choice: “The Art of Racing in the Rain,” with its canine narrator, the auto racing-loving Enzo.

Besides auto-racing and watching TV, Enzo loves his human family, and he recounts their (and his own) experiences — from hilarious to heartbreaking. Delving into themes about love, death, compassion and the special connections between humans and their animal companions, the novel has drawn comparisons to “Jonathan Livingston Seagull,” “The Alchemist” and “Life of Pi.”

Its many awards include a Seattle Times Best Book of the Year, an Oregonian Top-10 Northwest Book of the Year and a Pacific Northwest Book of the Year.

Kleinert says that the book “gave me back the joy of reading for fun’s sake during a time when I had to read so many work-related things. That makes it special to me.”



### The Little House series

by Laura Ingalls Wilder

Since its publication in the 1930s, “The Little House” series has sold more than 60 million copies in 100 countries — and inspired countless children to dream of life with the Ingalls family on the pioneer prairie.

For classical studies professor **Mary Bachvarova**, the books also provide valuable insights for adult readers. Bachvarova has read the series many times, both personally and to her children.

Initially, she enjoyed reconstructing how people lived in the past. Over time, she became intrigued by the way the books reshape Laura’s life, omitting a brother and a son who both died in infancy. She also became fascinated by Laura’s daughter, Rose Wilder Lane, who was involved in editing the books and became one of the founders of the libertarian movement.

According to Bachvarova, “‘The Little House’ stories of self-sufficiency outside the reach of the federal government were a construing of the past in order to justify present attitudes.”

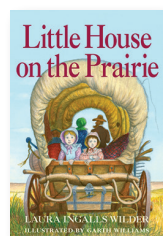

### The Awakening

by Kate Chopin

Although set at the end of the 19th century in New Orleans and southern Louisiana, Kate Chopin’s novella “The Awakening” resonated with **Abigail Susik** when she first read it a few decades ago as a teenager growing up on the west coast of Florida.

Considered scandalous when it was published in 1899, “The Awakening” is now seen as a landmark work of early feminism. The plot revolves around dissatisfied heroine Edna’s search for happiness and identity outside her marriage. As she rejects society’s restrictions, she undergoes a personal, artistic, sexual and spiritual revival.

Susik, an associate professor of art history, admires Edna’s revolt against subjugation and traditional views of women and motherhood. She says, “I loved her identity as a brave and essentially modern heroine who fought for personal freedom and fulfillment.”

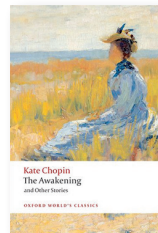

### Fox in Socks

by Dr. Seuss

Millions of giggling children can’t be wrong. With its torrent of tongue-twisters, “Fox in Socks” rocks.

**Michael Lockard**, associate professor of exercise science, was one of the numerous young fans of wordsmith and illustrator Theodor Seuss Geisel. With classics like “The Cat in the Hat,” “Horton Hears a Who!” and “Green Eggs and Ham,” Geisel’s alter ego, Dr. Seuss, transformed learning to read from a mundane chore into an imaginative adventure.

“When I was a kid, ‘Fox in Socks’ was the first book that made reading fun for me,” says Lockard. “It also taught me how someone could play with language to create something new and completely unexpected.”

Now a parent, Lockard has discovered a new appreciation of the book’s brilliance. He loves to see the pride on his own children’s faces when they master the rhymes and learn to “blab such blibber blubber” as if their “tongues were made of rubber.”

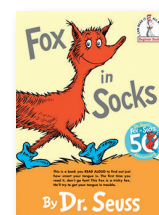

**Welcome to  
Bearcat World:  
News, views and  
happenings from  
the Willamette  
alumni community.**



# Bearcats All Over

**The Alumni Association provides opportunities for alumni to connect in person to socialize, network and celebrate our shared connections. Here's a peek at just a few of the many gatherings over the past nine months in WUAA chapters, clubs and beyond.**

1. Alumni explore the Oregon Coast with biology professor David Craig.
2. The Denver Club hosts a casual mixer.
3. Alumni connect at a District of Columbia Chapter mixer.
4. Fifty years after their own matriculation, members of the Class of 1969 prepare to light candles at the Matriculation Ceremony for the Class of 2019.
5. The WU/TIUA reunion in Tokyo, Japan, is an annual tradition.
6. Alumni in Los Angeles enjoy a gathering hosted by Megan (Crowell) Sheridan JD'88 and Peter Sheridan JD'88.
7. New York City Bearcats spend an evening at the Museum of Art and Design with designer Ralph Pucci and fashion designer Anna Sui.
8. Bearcat Explorers at the Ninomaru palace of Nijō Castle in Kyoto, Japan.
9. Delta Gamma alumnae enjoy a reunion in Aumsville, Oregon.
10. Alumni visit the Getty Center in Los Angeles, with a special talk with Getty CEO Jim Cuno '73 and a private tour of the grounds.
11. Willamette Valley Chapter Bearcats celebrate the holidays in Salem.





5

6

7



8

9



10

11

**Class Notes**

Remember to submit Class Notes to [willamette.edu/magazine](http://willamette.edu/magazine), or directly to Class Notes editor Daniel Johnson at [johnsond@willamette.edu](mailto:johnsond@willamette.edu). Your note may be edited for style and for space constraints.

**COLLEGE OF LIBERAL ARTS**

*Couples are listed under the graduation year of the person who submitted the class note, unless they specify otherwise.*

**1951**

**Correction: Alice (Adams) Schmidt** lives in Coquille, Oregon, not in Corvallis, as stated in the summer 2015 issue of Willamette magazine. In addition, her husband, Karl, passed away in 2007, not in 2002. We regret these errors.

**1957**

**K.C. Van Natta** and **Marilyn (Hanthorn) Baker** were married on Sept. 22, 2015, in Winnemucca, Nevada. They live at the Van Natta tall timber ranch outside of Rainier, Oregon.

**1961 55TH REUNION**

*Class Liaisons: Alice (Stewart) Pailthorp and Bill Richter*

**Sammie (Barker) McCormack** and her Delta Gamma sisters got together for their annual reunion in San Jose, California, last September. Those in attendance included **Barbara (Sherk) Schacht, Marcia (Humphrey) Olson, Jo (Gannon) Roughton, Karen (Madsen) Myers, Barbara (Royer) Graham, Karen (Henninger) Cheeld** and **Judy (Taylor) Lasswell**.

**1966 50TH REUNION**

**1967**

**John Bingham** published an e-book titled "Hangtown," an action-adventure-romance of historical fiction set in 1851 and featuring Willamette founder Jason Lee as an important character.

**1969**

*Class Liaison: Teresa (Krug) Hudkins*

**Glen Gibbons** received the United Kingdom Royal Institute of Navigation's Harold Spencer-Jones Gold Medal for his "outstanding contribution to navigation."

A journalist and publisher of international trade magazine Inside GNSS, Gibbons was presented the award by Prince Philip, Duke of Edinburgh.

**1971 45TH REUNION**

**1972**

**Dr. Glenn Richard Olds** is president and chief executive officer of St. George's University in Grenada, Spain. Glenn has served as an educator, physician and administrator during a distinguished career spanning more than 30 years.

**1974**

**Patrick Pine MBA'76**, chief administrative officer of the Robert F. Kennedy Medical Plan and Juan De La Cruz Pension, spoke at the Southern California State of Reform Health Policy Conference on Nov. 6 at LA Live.

**1975**

*Class Liaison: Patti (Lalack) Hutterli*

**1976 40TH REUNION**

**Sally Purbrick-Illek** writes: "I now live and work in Australia, but am seriously thinking of attending my 40th reunion at WU! My degree in biology from WU has helped me gain a number of interesting jobs (dairy farmer in Norway, teacher of all subjects in a one-room school in Washington, science teacher and school principal in Germany, math and science teacher in Malaysia, university lecturer in education and senior researcher in Australia) and also a few (sometimes crazy) unpaid positions, including snake catcher, wildlife educator, Reading Dog volunteer, coral reef preservation scuba diver and choir director."

**1981 35TH REUNION**

**1984**

*Class Liaison: Diane Babbitt*

**Dirk Zeller** was awarded the Certified Speaking Professional



Back Row: Barbara (Sherk) Schacht, Sammie (Barker) McCormack, Marcia (Humphrey) Olson, Jo (Gannon) Roughton. Front Row: Karen (Madsen) Myers, Barbara (Royer) Graham, Karen (Henninger) Cheeld and Judy (Taylor) Lasswell



Sally Purbrick-Illek '76



Sharon Gueck '92

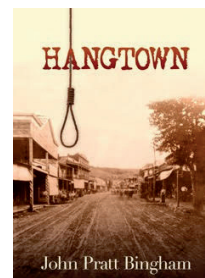

John Bingham '67

## From Willamette to Hollywood

As a music major at Willamette, **Paul Broucek '74** spent countless hours playing piano in the practice rooms. Back then, his passionate pursuit for the perfect tone and melody was mostly a solitary exercise. Today, as president of music for Warner Bros. Pictures, he's responsible for music heard by millions of moviegoers around the world.

Broucek is now a permanent Hollywood resident, but the Chicago native's first experience on the West Coast came at Willamette. Big-city dreams and the appealing non-traditional music program at Columbia College (Chicago) eventually lured him away from the Northwest, but his time at Willamette affirmed a love for music. Then, at Columbia he began to envision a new career path.

"I loved recorded music. I loved the idea of creating a music performance, whether it be natural and real or created in a studio," he says. "I decided that I wanted to be a music



producer."

With plenty of desire but little experience, Broucek moved to San Francisco after college, cutting his teeth as an intern in small recording studios. He was briefly sidetracked by a job on Francis Ford Coppola's classic Vietnam War film "Apocalypse Now," spending a year assisting the film's sound editors who went

on to win the 1980 Oscar for Best Sound Mixing.

While it was a thrilling experience, Broucek continued on his original career path and landed a job at one of the nation's top recording studios, Record Plant in Los Angeles. Many of the projects were recording music for movies, such as "The Blues Brothers" and "The Jazz Singer," and

Broucek discovered a natural affinity for film work.

In the 1990s, Broucek began to move into managerial and supervisory roles. In 1996, he joined New Line Cinema's music department, and eventually became its president after executive-producing the music for films such as "American History X" and the "Lord of the Rings" trilogy. He still credits that epic trilogy, which required producing and recording 14 hours of music, as his greatest career achievement.

At Warner Bros. since 2009, Broucek oversees the music production on upcoming blockbusters like "Batman v Superman: Dawn of Justice." After all these years, a love of music still infuses his work and life.

"I'm restless if I'm not working on something," he admits. "Whether it's my work or a pet project where I'm creating music on a more cellular level, it's an itch that I have to constantly scratch."

(CSP) designation by the National Speakers Association, the leading organization for the professional speaking industry. Dirk is one of just five professional speakers in Oregon and the only one in Central Oregon to have received the prestigious designation.

### 1985

**Eric Parker** became a Canadian citizen in December in Edmonton, Alberta. He has lived in Rocky Mountain House, Alberta, since 2009.

### 1986 30TH REUNION

### 1987

**Eric Scofield** is the chief development officer for Young Life. He and his wife, Marni, live in Colorado Springs, Colorado, with their two sons.

### 1991 25TH REUNION

### 1992

**Sharon Gueck**, a portfolio manager with Becker Capital Management, joined the board of directors of Portland-based nonprofit Store to Door, which supports independent living for seniors and people with disabilities by providing a low-cost, volunteer-based grocery shopping and delivery service.

### 1993

**Louie Bottaro** was promoted to director of student services for the College of Liberal Arts at Oregon State University in September. This new role expands on his academic advising role and includes career development, student recruitment and some study abroad programs.

### 1995

**Jennifer Chambers** received the National Association of College and University Business Officers 2015 Rising Star Award, given to future higher education leaders in finance, administration and business who are known for their innovative, meaningful contributions to the improvement of their profession and the efficiency of their institution.



Jennifer Chambers '95

## Learning Important Lessons from Darwin

When environmental science educator **Rebecca Detrich '00** got a call from National Geographic in February 2015, she thought her subscription had expired. In fact, she'd earned the trip of a lifetime, along with a rare educational opportunity for herself and her students.

Detrich was chosen as one of 35 educators from a field of more than 2,700 applicants for the prestigious Grosvenor Teacher Fellowship. The professional development program co-funded by National Geographic and Lindblad Expeditions sends educators from the U.S. and Canada to exotic locales around the world to study and bring back valuable lessons and experiences to their classrooms.

Last October, Detrich headed to the Galapagos Islands, a remote Pacific archipelago known for its many rare plant and animal species, as well as being the inspiration for Charles Darwin's theory of evolution. Amazed by the plants and animals that have adapted to the specific parameters of each island, she says, "It was astounding to see so much diversity within a relatively small area of the globe."

In her 10 days on the



islands, Detrich observed the rare and endangered Galapagos penguins, sketched the famed blue-footed booby birds (in whose honor she'd painted her toenails a matching shade), and was humbled in the presence of a 100-year-old giant tortoise.

Alongside such special memories, Detrich brought home new knowledge and insights to share with the students and instructors at Westminster Woods, a camp and conference center located in the redwood forest of Sonoma County, California. As the center's education director, Detrich supervises 15 teacher naturalists who serve about 200 students each week.

Detrich has incorporated into the center's curriculum more information about Darwin's theories. She's

introduced an evening program focused on how animals adapt to environmental forces. She's also led a series of staff seminars on the impact of El Nino weather patterns and plastics in the ocean on species like the Galapagos penguin and the albatross.

Just as her passion for environmental science and education was stirred during her time studying elephants in Tanzania on a Willamette study abroad program, Detrich hopes her work at Westminster Woods will inspire a new generation of teachers and scientists.

"I've always taken to heart the motto 'Not unto ourselves alone are we born,'" she says. "I've worked hard to serve our future generations, our global community and the environment."

**Megan (Finney) Stevens** published her first cookbook, "Eat Beautiful: Grain-free, Sugar-free and Loving It." She also maintains a blog called Eat Beautiful, which focuses on healing foods and nutrition, and is the owner of Vanilla Jill's, a paleo cafe in Eugene, Oregon.

### 1996 20TH REUNION

### 1997

**Traci (Shepard) Siriprathane** went on a sailboat cruise on Chesapeake Bay with Willamette friends **Carolyn (Leary) Bobb '95**, **Jamie (Cripe) Young '98**, **Emily (Vracin) Kosderka '96** and **Heather (Bullock) Langlois**. The group met up in Washington, D.C., to celebrate 20 years of friendship.

### 2000

**Nikolas Caoile** is in his 10th year as director of orchestral activities at Central Washington University, where he directs the symphony, chamber and opera orchestras. His ensembles have earned several accolades at the state and regional levels. Nikolas is also entering his fifth year as conductor and artistic director of the Salem Chamber Orchestra (Oregon) and his sixth year as music director of the Wenatchee Valley Symphony (Washington). This season, he will guest conduct the Lake Union Civic Orchestra and the Yakima Symphony Orchestra.

### 2001 15TH REUNION

In December, commercial banking officer **Joe Carmichael MBA'04** and City of Eugene economic prosperity programs manager **Amanda Noble-Flannery MBA'02** were named as two of Lane County's (Oregon) 20 Under 40 for 2015 by monthly business magazine Blue Chip.

To **Celeste (McKnight) Rizzo** and Marc David Rizzo, a daughter, Bianca Katherine Rizzo, born Aug. 19, 2015.

Right: Bianca Katherine, daughter of Celeste (McKnight) Rizzo '01



Far right: Caroline Marian, daughter of Jennifer (Allen) Billington '02



## 2002

To **Jennifer (Allen) Billington** and Charlie Billington, a daughter, Caroline Marian Billington, born Sept. 8, 2014.

## 2003

To **JoLee Liepman** and **Jeff Liepman '05**, a daughter, Payton Liepman, born Aug. 17, 2015.

## 2004

**Andrea Cobb** was elected to serve on the Tacoma Public Schools (Washington) board of directors.

**Dan Smart** is pharmacist-in-charge of MedOrganize Pharmacy in Poulsbo, Washington. He uses technology to help the elderly and those with disabilities manage medications to maintain their independence and reduce the burden to the healthcare system.

## 2005

*Class Liaison: Nathan Love*

**Rose Barker** finished her 75th swim across the Willamette River last summer. She was joined by several Willamette friends, including **Victoria Binning '14**, **Nelya Drofyak '10**, **Marshall Curry '13** and **Kendra Schaffer '13**. Rose is a certified identity theft and risk management specialist with Harvard Risk Management, and offers identity theft protection courses in the Mid-Willamette Valley.

**Robert Sumner** is press secretary for U.S. Sen. Mike Crapo of Idaho. The senator's primary media contact and spokesperson in Washington, D.C., he also promotes the senator's work through strategic outreach efforts to audiences across Idaho. Sumner previously served as an appointee to the George W. Bush administration and as deputy press secretary to U.S. Sen. **Lisa Murkowski JD'85** of Alaska.

**Annie (Brown) Trihan** and Guillaume Trihan were married on Oct. 24, 2015, at Hackney Town Hall in London. The couple, who met in London, hosted guests representing 13 different nationalities at the reception in a Covent Garden restaurant.



Dan Smart '04



Robert Sumner '05



Andrea Cobb '04



Carolyn (Leary) Bobb '95, Jamie (Cripe) Young '98, Traci (Shepard) Siriprathane '97, Emily (Vracin) Kosderka '96, Heather (Bullock) Langlois '97



Annie (Brown) Trihan '05 and Guillaume Trihan



Payton, daughter of JoLee Liepman '03 and Jeff Liepman '05



Left to right: Victoria Binning '14, Nelya Drofyak '10, Marshall Curry '13 and Rose Barker '05

Class Notes



Left to right: Andrew Beldin MBA'11, Desiree Hall '07, MBA'12, Alina (Vaynberg) Moore MBA'11 and Chris Moore JD'11



Maya Karp '07



Harper Zoe, daughter of Katie (Bechtel) Reich '06, MBA'12 and Tyler Reich '06



Kinsey Marie, daughter of Brian Nelson '08, MBA'09 and Jessica Nelson '09, MBA'10

2006 10TH REUNION

**John Atkins** joined the law firm Thompson & Knight LLP as an associate in Dallas, Texas.

**Darren McCoy** was one of 25 semifinalists selected for a Grammy Music Educator Award. Calling the selection a "wonderful honor," Darren credits much of his success to his time at Willamette, writing: "I took piano lessons from Dr. (Anita) King and Dr. (Jean-David) Coen and I took voice lessons from Dr. Wallace Long and professor (Allison) Swensen-Mitchell. I accompanied for men's ensemble, Voce Femminile, Chamber Choir, several students in private lessons, and worked in the music offices. During my senior year, I was choir president and learned the importance of professionalism in a music program. Through working with wonderful teachers and experiencing fantastic performances at locations such as South Africa and Carnegie Hall, I got much of the training that makes me who I am today. Without generous scholarships from the Statesman Journal and from Willamette, my life would be on a very different track."

To **Katie (Bechtel) Reich MBA'12** and **Tyler Reich**, a daughter, Harper Zoe Reich, born Aug. 17, 2015.

2007

**Desiree Hall MBA'12** and **Andrew Beldin MBA'11** were married on June 6, 2015, in Portland, Oregon.

**Alina (Vaynberg) Moore MBA'11** and **Chris Moore JD'11** were in attendance.

**Maya Karp** is an operations systems administrator at DreamWorks Animation, providing software, hardware and network support to more than 2,000 employees.

2008

To **Brian Nelson MBA'09** and **Jessica Nelson '09, MBA'10**, a daughter, Kinsey Marie Nelson, born April 24, 2015. Brian celebrated four years with Bank of America in Portland, Oregon, in January. Jessica is a buyer for Tektronix Service Solutions.

2009

**Aaron Otto** and **Laura (Braithwaite) Otto '12, MBA'13** were married on Oct. 4, 2015, in Seattle. **Ethan Bancroft** was the best man, and many other Willamette alumni were in attendance, including **Sierra Solluhub '11, Katie Hanschen '10** and **Lindsey Dennis '14**.



The wedding of Aaron Otto '09 and Laura (Braithwaite) Otto '12, MBA'13

## 2011 5TH REUNION

*Class Liaison: Shaffer Spaeth*

**Chi Nguyen-Ventura MBA'12** successfully campaigned for a seat on the King City (Oregon) City Council. Her appointment came a month after her 33rd birthday, making her the youngest serving councilor and the first Asian-American to serve in the city's history.

## 2012

*Class Liaison: Rafael Baptista*

**Cathy Monahan** moved to France last September to begin a master's program and is preparing to study in Morocco.

**Lauren Richards** and Eric Brown were married on Sept. 5, 2015, in San Francisco.

## 2013

*Class Liaison: Molly Ward*

**Zane Scheuerlein** is a multimedia specialist at the University of Chicago's Institute of Politics, an organization founded and directed by President Barack Obama's former chief campaign strategist, David Axelrod. Zane serves as assistant producer of the *Axe Files*, a popular podcast series of revealing interviews with key global political figures, such as Bernie Sanders and Nancy Pelosi.

**Lauren Vannini** was promoted at the Portland State University Foundation to assistant director of development for the School of Business. Last fall, she also got together with

**Breck Lindauer MAT'09, Kaileigh Westermann '12, Maya McFaddin '12, Alexa Beeson '14, Adrian Lewis '11, Becca Josephson '14** and **Jojo DeLong '15** to tailgate before the Willamette-Linfield football game.



Zane Scheuerlein '13

## 2014

*Class Liaison: Alex Schrimp*

**Hugh Houghton** is a FEMA Corps field team leader as part of his pledge to perform 11 months of national service with AmeriCorps National Civilian Community Corps (NCCC).

## 2015

*Class Liaison: Natalie Pate*

**Kayley Abrams** is a development associate at the Commonwealth Club in San Francisco, the oldest and largest public forum in the nation. Kayley says: "I am so excited to work here, and I believe this will be a good stepping stone towards a career in international relations."

**Maria Hernandez**, who was selected last spring as Willamette's first Humanity in Action fellow and was placed in Paris, has been chosen for the Coro Fellows Program. Every year, the prestigious nine-month program selects 12 young leaders to work collaboratively in business, nonprofit and government settings in urban areas. Maria will be placed in San Francisco.



Lauren Richards '12 and Eric Brown



Left to right (back row): Breck Lindauer MAT '09, Lauren Vannini '13, Kaileigh Westermann '12, Maya McFaddin '12, Kyla Postrel, Alexa Beeson '14, Adrian Lewis '10. Left to right (front row): Becca Josephson '14, Jojo DeLong '15

**SUBMIT CLASS NOTES** at [willamette.edu/magazine](http://willamette.edu/magazine) or directly to class notes editor Daniel Johnson at [johnsond@willamette.edu](mailto:johnsond@willamette.edu). Your note may be edited for style and for space constraints.



Tara Schleicher MM/JD'95



Emily Carrick MBA'03



Kyle Abraham JD/MBA'05



Alexandra Ness MBA'05

### Be a Class Liaison

Want to see more class notes from your classmates? Help keep your class connected and volunteer to be a class liaison! The WUAA and the alumni office are constantly in contact with alumni, but nothing is more powerful than the personal touch a class liaison can provide.

Contact the Office of Alumni & Parent Relations at 503-375-5304 or [alumni@willamette.edu](mailto:alumni@willamette.edu) for more information.

## GRADUATE SCHOOL OF EDUCATION

**Ricardo Larios MAT'07** received a Milken Educator Award in January. The nation's preeminent teacher recognition program, known as "the Oscars of teaching," aims to attract, retain and motivate outstanding talent to the profession. Ricardo is a social studies teacher at Waldo Middle School in Salem, Oregon.

## ATKINSON GRADUATE SCHOOL OF MANAGEMENT

**Don Seufert MBA'79** was a key expert and workshop leader at The Hague Academy for Local Governance in November. The event included country managers and development professionals from an array of EU and UN donors and implementing agencies, working in places such as Burundi, Ukraine, Nepal, Afghanistan, Lebanon, Sudan, Egypt and Palestine.

**Mark Schussler MBA'84** completed a three-month stint as interim chief of staff for the Maine Conference United Church of Christ. While serving in the role, he continued overseeing financial management and several other key administrative operations as the conference's business manager. He lives in South Portland, Maine, and welcomes contact from friends, alumni and students seeking internships or projects.

**Punit Renjen MM'86**, Deloitte Global CEO and Willamette University trustee, was selected to the Association to Advance Collegiate Schools of Business International's inaugural "Influential Leaders" list.

**Nando Miño MBA'00**, **Javier Miño MBA'02** and **Stacy West '06, MBA'12** have opened a U.S. branch of Grupo Macro, a professional training organization headquartered in Quito, Ecuador. The fourth international office for Grupo Macro, the U.S. office specializes in Spanish language training for professionals, as well as game-based intercultural competency trainings. Stacy is the general manager of the office in Fort Collins, Colorado.

**Emily Carrick MBA'03** writes: "This August marks my 10-year anniversary with PacificSource Health Plans as a Medicare sales executive in our Bend (Oregon) office. I'm putting everything Debra Ringold taught me to good use!"

**Kyle Abraham JD/MBA'05** has been named a partner of the Barran Liebman law firm in Portland, Oregon. Kyle practices both traditional labor law and employment law, and is one of the only attorneys in Oregon certified by the Association of Workplace Investigators to conduct workplace investigations. He frequently trains on employment law issues and serves on the board of the Portland Human Resource Management Association.

**Alexandra Ness MBA'05** was promoted to the position of internal auditor for the corporate audit unit of Sapa, an aluminum manufacturer based in Europe. In her new role, Alexandra will temporarily relocate to the company headquarters in Oslo, Norway.

**Tara Schleicher MM/JD '95**, a shareholder with the Farleigh Wada Witt law firm in Portland, Oregon, is included in the 22<sup>nd</sup> edition of The Best Lawyers in America for Litigation - Bankruptcy. She is certified by the American Board of Certification as a business bankruptcy specialist.

**Diana Ursachi MBA'10** won the 2015 Award for Entrepreneurship at the annual gala organized by the French Chamber of Commerce in Romania (CCIFER). Her project, Guidecademy, includes a best-selling guide for people who want to study and work abroad, as well as training and consulting services to help companies that have difficulties in retaining employees of the Millennial generation (b. 1978-1989). The guide came out as a tribute to her incredible experience at Willamette, for which she thanks the generosity of private donors and the Fulbright program.

# ALUMNI NEWS BITS

## Join us for **ALUMNI WEEKEND 2016** SEPTEMBER 22-25



**ALL ALUMNI ARE INVITED TO COME BACK TO CAMPUS** to connect with Bearcats across the schools and generations! At Alumni Weekend you'll have the opportunity to engage in a huge variety of activities and programs that showcase Willamette alumni, students and faculty. In addition to guest speakers, panels and presentations, we'll have reunions, parties and one-of-a-kind experiences on campus and in the surrounding area.

Last year marked the largest Alumni Weekend on record. Come back in 2016 to experience it for yourself. **Always a Bearcat!**

### Thanks to the WUAA Alumni Weekend Committee

Kathy (Cook) Wraith '85  
MBA '86, chair  
Morgan Gratz-Weiser '13  
Bob Heck '07, MBA '11  
Andrés Oswill '15  
Cathy Tronquet '70  
Crayton Webb '94

### Switchboard Surges

Activity on Willamette Switchboard spiked just before the holidays. More than 200 new users signed up during November and December, and engagement increased by 86 percent. And the best part is: Our Switchboard community is still growing, which means our alumni network will only get stronger in 2016.

Thanks to all alumni who helped fellow Bearcats on Switchboard. If you're not already on, it's fast and easy to sign up at [willametteswitchboard.com](http://willametteswitchboard.com).

### Updated Alumni Website

The Alumni Association's web space has undergone a renovation. Visit [willamette.edu/alumni](http://willamette.edu/alumni) to see the organizational revamp, which prominently features links to the Alumni Directory, information about our activities and community, and an interface that's easier to navigate. While we've added new information and removed the clutter, there's certainly still room for improvement, so please send your feedback or suggestions to [alumni@willamette.edu](mailto:alumni@willamette.edu).

### Organizations Connect Alumni

WUAA volunteers in chapters, clubs and groups are busy planning opportunities for Bearcats to gather and connect in a variety of ways. Whether it's the Portland Law Alumni Network putting on a CLE course and networking mixer, a chapter talk with a member of the Willamette faculty, a club outing to a sporting event, or one of the many other gatherings in the works, there are endless opportunities to connect. Watch for announcements in the monthly WU Alumni Connection e-newsletter, and view the full list of activities at [willamette.edu/alumni](http://willamette.edu/alumni).

### Get Involved!

Volunteers are vital to the continued growth and success of the WUAA. There are numerous ways to get involved to build connections within our Bearcat community, as well as help support students and fellow alumni. No matter what you can offer, the WUAA needs you. Be a part of it! See more information at [willamette.edu/alumni/activities](http://willamette.edu/alumni/activities).

## In Memoriam

### 1930s

#### Irma (Oehler) Abbott '38

March 7, 1916 – Oct. 2, 2015  
Irma Laura Abbott was born in Hawkeye, Iowa. At Willamette, she joined Phi Beta Kappa before graduating with a degree in history. After World War II, Irma and her husband, **George Abbott '40**, moved to California to raise their family. The couple eventually settled in El Cerrito, California, where they were residents for 44 years, both teaching in the Richmond Unified School District. Her husband and sister, **Gertrude (Abbott) Bergman '32**, preceded her in death. Survivors include sons Peter and Rick.

### 1940s

#### Gwendolyn (Griffith) Williams '42

Sept. 15, 1920 – July 1, 2015  
Gwendolyn Mae Williams was born in Yakima, Washington. After earning her bachelor's degree in physical education from Willamette, she taught physical education and health at Lincoln High School in Tacoma, Washington, and at her alma mater, Olympia (Washington) High School, for 26 years, retiring in 1977. During her career in education, Gwen also coached tennis, leading several of her teams to state championships. Away from work, she enjoyed traveling, gardening and taking care of her dogs. Survivors include her sister, Pauline.

#### Delma (Jones) Klassen '43

April 28, 1918 – Aug. 16, 2015  
Delma Jean "DJ" Klassen was born in Fallon, Nevada. When DJ was young, her family moved to Oregon, eventually settling in Grants Pass. After graduating from Grants Pass High School, DJ attended Willamette, where she met her future husband, **Al Klassen '40**. During World War II, DJ worked for the U.S. Army Counter Intelligence Corps in California. After the war, she returned to Grants Pass, where she and Al raised their three children. In her later years, DJ helped establish a memorial fund and scholarship for high school classmate Johnny Hampshire, an ace pilot who was shot down during WWII. Survivors include daughter Suzanne and son Bruce.

#### J. Warren Carkin '44

April 10, 1922 – Sept. 17, 2015  
John Warren Carkin was born in Medford, Oregon. After moving to Salem as a youth, Warren attended Salem High School and Willamette. In 1943, Warren enlisted in the U.S. Army. Although wounded in Europe during World War II, he returned home safely and completed his education, earning a degree in business administration from the University of Oregon. In 1951, Warren and his wife, Betty, moved to Portland, Oregon, where he received his architectural license. Later, Warren started an architecture firm in Salem, where he worked for 31 years. He was selected Salem's First Citizen in 1980 for his community service and was inducted into North Salem High School's Hall of Fame in 2012. His wife of 66 years, Betty, and his brother, **Earle Carkin '32**, preceded him in death. Survivors include his sister, **Jean (Carkin) Sanesi '45**; and daughters Jan and Nancy.

#### Shirley (Blackman) Barber '46

Nov. 10, 1924 – Sept. 20, 2015  
Shirley Louise Barber was very active at Willamette, including membership in Alpha Chi Omega sorority, but ended up completing her bachelor's degree in home economics at Oregon State University. She worked at Safeco Insurance for 25 years, retiring as a claims adjuster in 1989. Along with her husband, Robert, she was later a member of Willamette's R.A. Booth Society. In 1995, the couple established the Blackman/Barber Scholarship, which is awarded annually to students majoring in biology, chemistry or physics. Survivors include her brother-in-law, **Richard Barber Sr. JD'55**, and nephew **Richard Barber Jr. '78, JD'81**.

#### Frances (Mansfield) Cooke '47

Sept. 8, 1926 – May 22, 2015  
Frances Patricia "Pat" Cooke was born in Winthrop, Minnesota. In 1934, her family moved to Salem and later she graduated from Willamette, where she was a member of Alpha Chi Omega sorority. After college, she and her husband, Bill, started a family and moved to Tacoma, Washington. Pat worked for Weyerhaeuser Co. for more than 15 years, retiring in 1993. Survivors include children William, Mary, Robert and Carol.

## Former Dean Led AGSM to New Heights

### George Dale Weight

March 25, 1934 – Nov. 29, 2015



George "Dale" Weight was born to Sheldon and Florence Weight in Salt Lake City. Dale was an active and interested high school student who enjoyed tinkering with electronics and participating in the ROTC program. He also developed a strong religious faith as a member of the Church of Jesus Christ of Latter-day Saints, serving a mission in western Canada following his graduation from West High School in Salt Lake City in 1952.

After returning from his mission, Dale met Carilee Kesler, and in the summer of 1959, the couple wed in the Church of Jesus Christ of Latter-day Saints Temple in Salt Lake City. Dale then earned a bachelor's degree in accounting from the University of Utah and a doctorate in finance and business economics from the University of Oregon.

After college, Dale embarked on a successful career in banking. He worked for the Federal Reserve Bank in Cleveland and Pittsburgh before moving to the Syracuse Savings Bank in Syracuse, New York, where he served as president and CEO for 12 years. Later, he served as president and CEO of Benjamin Franklin Savings and Loan in Portland, Oregon.

Following his banking career, Dale brought his wealth of business knowledge and experience to Willamette, serving as the dean of the Atkinson Graduate School of Management from 1990-1997. During his tenure, AGSM became the first school in the world to hold dual accreditation from the American Association of Collegiate Schools of Business (AACSB) and the National Association of Schools of Public Affairs and Administration (NASPAA). The school also opened a new computer lab and instructional center, and it gained recognition as one of the nation's top schools by Businessweek.

A consummate professional, Dale also knew how to cut loose. During AGSM's traditional Brownwater festivities each spring, he floated in an inner tube down the Mill Stream in his signature tuxedo T-shirt.

Family, friends and the communities of which Dale was a part will remember him fondly for his volunteer service to local organizations, including the Boy Scouts of America, the Portland Rose Festival, the American Heart Association and the Oregon State Board of Education. Dale also remained heavily involved with the Church of Jesus Christ of Latter-day Saints throughout his life, serving in various leadership positions including stake president of the Syracuse stake; regional representative for the Northwest area; executive secretary to the presidency of the Northwest Asia Office in Tokyo; and president of the Portland, Oregon, temple.

Survivors include his wife of 56 years, Carilee; younger brother Melvin; daughters Camille Tingey, Kristene Allen, Denise Stafford, Marcie Vorkink and **Nancy Bair '97**; 21 grandchildren; and eight great-grandchildren.

**Donald E. Link '48**

Feb. 19, 1922 – July 1, 2015  
Donald Ellis Link was born in Astoria, Oregon. His studies at Willamette were interrupted when he enlisted in the U.S. Navy during World War II. After the war, he went to work for Uniroyal Tire Co., retiring in 1984. Later, he embarked on a second career as a successful real estate broker. Survivors include children Karen, Cathryn and Donald.

**Rosemary (Sykes) Gladow '49**

Sept. 22, 1923 – Sept. 16, 2015  
Rosemary Gladow was born in Pendleton, Oregon. She graduated from Grant High School in Portland, Oregon, and then worked in airplane and shipyard factories during World War II. After the war, Rosemary moved to Salem, where she attended Willamette and later volunteered in public schools, St. John Lutheran Church and other nonprofit organizations. She will be remembered as an avid artist with an independent spirit and a great sense of humor. Her husband of 67 years, Wesley, preceded her in death in 2015. Survivors include children Genice, Jeff and Grant.

**Rev. Meredith R. Groves '49**

Sept. 24, 1925 – Aug. 24, 2015  
Meredith Robert Groves was born in Salem. After graduating from Seaside High School in Seaside, Oregon, he served his country in World War II, seeing combat as a member of 86th Blackhawk Division, 341st Infantry of the U.S. Army. During the war, he decided to become a Methodist minister and pursued his calling by earning degrees from Willamette and the Perkins School of Theology at Southern Methodist University. He served as a pastor for several Methodist churches over the course of a four-decade career before retiring in 1991. Survivors include his wife of 68 years, Dorothy; brothers **Vernon Groves '53** and **Leland "Eugene" Groves '57**; sister **Shirley (Groves) Clifford '53**; and children Jay, David, **Linda (Groves) Crenshaw '78** and Alan.

**1950s****Dr. Loy E. Cramer M.D. '50**

Dec. 20, 1928 – Aug. 19, 2015  
Loy Ermal Cramer completed his undergraduate studies at Willamette and his graduate education at the University of Oregon Medical School

before going on to a successful career as an orthopedic surgeon. Survivors include his wife of 55 years, Ellen, and children Jon, Jill, Pamela and Jeffrey.

**John R. Brown Jr. '51**

July 14, 1929 – Oct. 27, 2015  
John "Jack" Ralph Brown was born in Chicago. When he was a young boy, his family moved to Oregon. At Willamette, Jack met many lifelong friends and his future wife, **Jean (Stewart) Brown '53**. Following his service in the U. S. Army during the Korean War, Jack received his master's degree in journalism from the University of Oregon. He went on to serve as the editor of the Central Oregonian in Prineville, Oregon, before moving to Lake Oswego, Oregon, in 1960 to work in public affairs and communications until his retirement in 1994. Survivors include his wife; sister, **Maxine (Brown) Callinan '56**; children Jim, Rich, Don and Julie; and nephew, **John Kent '78**.

**Alene (Axelson) Cate '51**

July 23, 1929 – Oct. 13, 2015  
Alene Cate was born in Orleans, Nebraska, and at a young age moved with her family to Salem. After attending Willamette, she got married and moved to a farm in Lebanon, Oregon. She and her husband, Bob, lived there for the rest of their lives, raising a family, and maintaining the land and a grain brokerage business. Arlene will also be remembered for her love of cooking and gardening. Survivors include children Virginia and Jim.

**Ruth (Patterson) McPherran '51**

June 20, 1931 – Sept. 13, 2015  
Ruth Anne McPherran was born in Klamath Falls, Oregon. After attending Willamette, she completed her education at the University of Oregon, graduating in 1951. She then embarked on a 47-year teaching career that included stops at Prairie City, Grant Union and Mt. Vernon high schools in Oregon before retiring in 2000. Away from work, she was an active member of the Prairie Baptist Church and volunteered throughout the community in a number of roles, including helping to run the recycling center in Prairie City for many years. Survivors include children Leslie, Kathy, Jennie, Sharon and Patrick.

**Maureen (Taylor) Hedeem '53**

Feb. 28, 1931 – Nov. 3, 2015  
Maureen Joyce Hedeem was born in Coquille, Oregon. At Willamette, she met her husband, **Wesley Hedeem '52**. She then went to San Jose State University to finish her degree in elementary education and became an elementary school teacher. Joyce and Wes eventually settled in Coquille, where Joyce worked, volunteered, was a member of a local church and raised her family. She was preceded in death by her husband and uncles **Paul Roeder '25** and **Wesley Roeder '32**. Survivors include daughters Karen, Jan and Diane, and siblings Bob and Helen.

**Don E. Robinson '53**

June 4, 1931 – July 10, 2015  
Don Earl Robinson was born in Seattle. After attending Whitworth College in Spokane, Washington, he moved with his wife to Salem to finish his undergraduate degree at Willamette. Don then began a career selling life insurance, working several decades with Business Men's Assurance. Away from work, Don enjoyed ranching, drawing, reading, history, studying the Bible, riding horses and fishing. Don was also a talented athlete, and once held the Washington state record for the javelin. Survivors include his wife, Joan, and children Kyle, Marsha Jo and Dirk.

**Colleen (McCord) Toombs '53**

Aug. 19, 1930 – May 11, 2015  
Colleen Toombs was raised in Baker City, Oregon. After Willamette, she held several jobs but is best remembered for her 20-year career at Malheur Federal Credit Union in Ontario, Oregon, where she and her husband, Leo, also owned family business Toombs Janitorial Supply. Colleen was also very involved in the community, serving on several boards and committees and as a volunteer with organizations such as the Special Olympics. Survivors include children Cindy, Chuck, Scott and Phil.

**Col. Joseph D. Formick '53**

Oct. 29, 1926 – June 28, 2015  
Joseph Dennett Formick was born in Salem. He enlisted in the U.S. Army during World War II and was stationed on Okinawa, Japan. After the war, Joe earned a bachelor's degree from Willamette and a master's degree from the Oregon College of Education. He taught in the Salem School District before re-

entering the Army in 1965, working his way up to the rank of colonel before retiring to Canby, Oregon. Survivors include his wife, Marjorie; children Pam, Paul and Jay; and stepchildren Wanda and Jeanne.

**Mary (Turnacliiff) Strauch '55**

Aug. 9, 1933 – Aug. 26, 2015  
Mary Maude Turnacliiff-Strauch was born in Whitefish, Montana, and grew up in Sacramento, California. At Willamette, Mary joined Pi Beta Phi sorority. Later, she returned to Sacramento, spending her remaining years there with her two dogs. Mary will be remembered for the love she showed others. Survivors include daughters Deon and Susie, and stepdaughter Connie.

**Ward Armstrong '55**

Aug. 16, 1935 – Sept. 5, 2015  
Ward Armstrong attended Willamette for two years, a time in which he met his wife, **Donna (Leonard) Armstrong '57**. Ward then transferred to Oregon State University, graduating with a degree in forestry. In 1966, Ward earned his law degree from Lewis & Clark College, passed the bar and embarked on a career as a successful lobbyist and public policy specialist. Before retiring in 1994, he held several high-profile positions in the forestry industry. Survivors include his wife; children Ken, Mark and Diane; and brothers **Hugh Armstrong '57** and Richard.

**Dr. Frank A. Moore Jr. '56**

June 15, 1935 – Sept. 26, 2015  
Frank Arthur "Dick" Moore was born in Carmel, California, and graduated from Sequoia High School in Redwood City, California. In 1952, Dick enrolled in pre-med at Willamette, where he joined Beta Theta Pi fraternity, played for the golf team and met many lifelong friends. He went on to study at the University of California Medical School, earning his M.D. before completing specialty training in obstetrics and gynecology. Later, Dick established his own ob-gyn clinic in Medford, Oregon, the first of its kind in the state to have certified nurse midwives. A foremost leader in his field, Dick also served as the president of the Pacific Northwest Obstetrical and Gynecological Association. Survivors include his wife, Marlene; daughter, Wendy; and stepdaughter, Kelly.

## A Lifelong Scholar, Educator and Bearcat

**James H. Hitchman '54**

**Nov. 17, 1932 – Nov. 18, 2015**



James Harold Hitchman was born in Los Angeles. He graduated from Newport Harbor Union High School in Newport Beach, California, before moving to Salem and becoming a lifelong Bearcat.

At Willamette, Jim quickly became actively involved on campus, showing off his many talents. As the formation leader for the class of 1954 in Freshman Glee, he helped orchestrate four victories, an astounding achievement

accomplished only one other time in Glee's 96-year history (by the Class of 1936). He also won an outstanding actor award, set a conference shot put record and displayed his smarts as a senior scholar in history. Clearly someone his classmates looked up to, Jim was also elected student body president.

After graduating from Willamette with a bachelor's degree in history, Jim continued his education at the University of California at Berkeley, earning his master's in history. Then, after serving his country as a lieutenant in the U.S. Marine Corps, he began a career in education, first working as an admissions counselor for Westminster College in Salt Lake City. He went on to teach in the history department at Portland State University, winning an outstanding teaching award during his short tenure there.

After returning to Cal Berkeley to receive his doctorate in philosophy, Jim spent most of his career teaching history at Western Washington University. Dean of students for two years (1967-1969), he also spent time guest lecturing and traveled to the University of Mysore in India as a Fulbright lecturer.

An exceptional writer and historian, Jim published six books and 30 articles on the U.S. and Cuba, Willamette, liberal arts colleges and maritime history. In a number of essays about Willamette, he wrote about the class of 1954, the track team and Freshman Glee.

Jim also maintained contact with the university as an admissions counselor, fundraiser, and member of the Alumni Board and Board of Trustees, capping his service by helping establish an endowed scholarship for his class.

In retirement, Jim liked to garden, sail and lecture at the Oregon Coast Learning Institute. Continuing to compete in athletics at a high level, at the age of 70 he participated in the hammer throw in the 2003 USA Masters Outdoor Track & Field Championships.

James' aunt, **Marie S. Corner '22**, predeceased him in early 2015. Survivors include his wife, **Carolyn (Crane) Hitchman '54**; brother **John A. Hitchman '56**; ex-wife **Marie C. Corner '53**; three children and six grandchildren; nephews **Thomas Hitchman '82**, **John M. Hitchman '84** and **Jeffrey Corner '86**; and niece **Catherine Hitchman '83**.

**Carol (Litchfield) Rehfuss '56**

April 28, 1934 – June 28, 2015

Carol Rehfuss was born in Corvallis, Oregon, and grew up in Newport, Oregon. At Willamette, she studied home economics and music, and met her husband, **John Rehfuss '56**. After college, she began a long teaching career, later earning her master's in special education from Cal State Sacramento. Survivors include brothers **Ralph Litchfield '60** and **Richard Litchfield '63**; children Debbie, Brent and Todd; and cousins **Joanne McGilvra Rose '60**, **Paul McGilvra '61** and **James Dixon '64**.

**Patricia E. Brandt '57**

July 31, 1932 – Sept. 15, 2015

Patricia Elizabeth Brandt was born in Gresham, Oregon. She received undergraduate degrees from Mt. Angel Women's College and the University of Portland. She then earned graduate degrees from Willamette and the University of Denver before spending most of her working life as a librarian at Oregon State University. Patricia was also a talented musician and award-winning writer who published several books and articles on Northwest history. Survivors include siblings Katherine, Carol, Mary Rose and John.

## 1960s

**John A. Sanford '61**

Dec. 7, 1939 – Oct. 30, 2015

John Austin Sanford was born in Decorah, Iowa, and raised in Silverton, Oregon. He graduated from Silverton Union High School, where he played football for a state championship team. He then graduated from Willamette with a degree in economics. John enjoyed a 21-year career at Blazer Industries before retiring in 1999. Many in the community knew John through his longtime involvement with the Silverton Kiwanis Club, an organization for which he served as president for two terms. Survivors include children Kimberly, Scott and Ann.

**Joan (Pemberton) Cravens '61**

May 20, 1939 – June 7, 2015

Joan Cravens was born in Portland, Oregon, and grew up in Salt Lake City. After attending Willamette, she completed her bachelor's degree at the University of Washington. She then went on to earn a master's

degree at Ohio State University before teaching English and working as a secretary during the mid- to late 1960s. After a move to Ames, Iowa, she started a family with her husband, Hamilton, and wrote and edited for Better Homes and Gardens books and magazines. Later, she launched a freelance writing/consulting business. Survivors include children Heather and Christopher; siblings Patricia, James and Joy; aunt **Margaret (Pemberton) Fisher '44**; and cousin **Marie Hitchman '53**.

**Carol (Hille) Hill '61**

March 30, 1939 – Oct. 23, 2015

Carol Ellen Hill was born in Salem and grew up in Colfax, Washington. After returning to Salem to attend Willamette, she continued her education at Eastern Washington University, where she graduated with degrees in psychology and education. In 1969, Carol and her husband moved to Olympia, Washington. There, she turned her enjoyment of ceramics into a thriving family business. Survivors include her husband of 55 years, Melvin; children Cinda and Mark; and sister, Joan.

**Ronald G. Young '61, LLB'63**

May 15, 1936 – June 23, 2015

Ronald George Young was born in Shelton, Washington. After graduating from Albany High School in Albany, Oregon, he served in the U.S. Marines. He went on to Willamette, where he graduated third in his class from the College of Law. In the 1960s, Ron served as a district attorney for Linn County, and later opened a private law practice in Albany. He was also one of the founding board members for Linn-Benton Community College. Survivors include children Ron and Diana.

**Judith A. Drais '62**

April 28, 1940 – Aug. 28, 2015

Judith Ann "Judi" Drais was born in Champaign, Illinois. After attending Willamette for one year, she transferred to the University of Oregon and graduated with a bachelor's degree in English. In 1964, Judi was shot in the back and had to use a wheelchair for the rest of her life, but the injury didn't stop her from pursuing her education and career. She taught high school English and language arts for 34 years, during which time she earned a master's in the teaching of writing from the University of California at Berkeley. After retiring, Judi remained active in several

organizations, including the Southern Oregon Historical Society. Survivors include her adopted son, Brad.

#### **Rodney L. Nyleen '62**

May 27, 1931 – Sept. 25, 2015  
Rodney "Rod" LeRoy Nyleen was born in Clearbrook, Minnesota. After serving in the U.S. Navy, he received a bachelor's degree in sociology from Willamette. He later became a part-owner and operator of a retail store in Burns, Oregon. Rod was an avid pilot, fisherman, hunter and golfer. He was also a member and twice Exalted Ruler at the Elks Lodge in Burns. Survivors include his brother, Clifton.

#### **Everette H. Williams '63**

July 16, 1941 – Sept. 1, 2015  
Everette Holt Williams was born in Denver and later moved to Oregon with his family. After graduating from Willamette with a bachelor's degree in political science, Everette studied at UCLA and the University of Oregon before earning master's degrees in teaching at Portland State University and in international studies from the University of Wyoming. He enjoyed a long career of teaching English as a second language in countries including Iran, Kuwait, Japan, Turkey, China and Hungary.

#### **Lewis M. King '67, JD'70**

Aug. 16, 1946 – Sept. 30, 2015  
Lewis Marable King was active in student government, intramural sports and Sigma Chi fraternity while at Willamette. He was also known for playing the role of mascot Barney Bearcat during his time as an undergraduate. Survivors include his wife, Roseann, and daughter, Ashley.

#### **Bruce A. McLeod '69**

April 6, 1947 – Aug. 8, 2015  
Bruce Angus McLeod was born and raised in Palo Alto, California. After earning his bachelor's degree in history from Willamette, he entered the U.S. Navy. He served in Alaska and the San Francisco Bay Area until completing his active duty in 1974. Bruce and his family then relocated to Tacoma, Washington, where he worked in retail and sales. He later became an insurance agent and moved to West Richland, Washington. Survivors include his wife, Nancy; sister, Janyne; and children Jennifer, Deborah, Richard and Shauna.

## 1970s

#### **Judith A. Paul '72**

Oct. 27, 1950 – Sept. 27, 2015  
Judith Ann Paul was born in Bigfork, Montana. After receiving her degree in music education from Willamette, Judy took her first job teaching middle school music in Sitka, Alaska, and used time off each summer to earn a master's degree in music education from the University of Montana. She then became a professor of music at Western Montana College.

#### **Joseph H. Whitsett '73**

March 23, 1951 – Sept. 2, 2015  
Joseph Harold Whitsett graduated from North Bend High School in North Bend, Oregon, before attending Willamette. After college, Joe became a certified inhalation therapist and founded the first union for non-certified medical employees in the state of Oregon. Later, he worked as a representative for the Retail Clerks International Union and served as a merchant marine for Sause Bros., an ocean towing company. Joe also served as the mayor of Bandon, Oregon, from 2002-04. Survivors include his wife, Darla; mother, Winfred; stepfather, Cecil; and brothers Jerry and Jim.

#### **David B. Goff '79**

Feb. 2, 1957 – Nov. 2, 2015  
David Brian Goff attended Medford High School in Medford, Oregon, graduating with honors. A talented swimmer, David was awarded an athletic scholarship to Willamette, where he spent two years. Survivors include parents Alice and Jean, and sister Kerry.

## 1980s

#### **Elizabeth A. Spoon '86**

May 2, 1964 – Nov. 5, 2015  
Elizabeth "Lisa" Ann Spoon attended St. Mary's Academy in Portland, Oregon, before earning her bachelor's degree from Willamette. She worked as a membership administrator at Regence Blue Cross Blue Shield of Oregon for nine years. Survivors include her husband, Wally; children William, Allyson and Danielle; mother, Viola; and brother, Christopher.

## 1990s

#### **Annette L. Dietz '96**

Sept. 12, 1972 – Aug. 4, 2015  
Annette Dietz was born in Albuquerque, New Mexico, and grew up in Eugene, Oregon. After attending Willamette, she earned a graduate degree from Southeastern Louisiana University. She was an educator for 19 years, and specialized in working with students with disabilities. Survivors include parents Claudia and Robert.

## 2000s

#### **Duncan S. Robertson '05**

Nov. 12, 1982 – Nov. 18, 2015  
Duncan Sadat Robertson was born in Seattle. At Willamette, he wrote film criticism for *The Collegian*, co-produced art festivals, worked at *The Bistro* and made many lifelong friendships before earning his bachelor's degree in English. In 2010, he moved to Los Angeles to pursue a career in the entertainment industry, and accrued producer credits on several television shows. He will be remembered for his compassion for others and his love of travel and film. A memorial fund at Willamette has been established to commemorate Duncan's life. Survivors include his wife, Erica; mother, Sharon Fisher '72; fathers, Bruce Robertson '70 and John; and sister, Miko.

#### **Sierra V. Carroll '16**

Aug. 23, 1994 – Sept. 28, 2015  
Sierra Carroll died suddenly while attending Willamette. Sierra will be remembered for her intelligence, sense of humor and grace. She cared deeply for people, brought joy into situations and was able to resolve conflict with an insight beyond her years. Survivors include her mother, Jill Loforte Carroll; father, Daniel Carroll; her sister, Kelly Carroll; her maternal grandparents, Anthony and Janet Loforte; and many aunts, uncles and cousins.

#### **Sonya Essaadi '17**

Jan. 10, 1995 – Dec. 13, 2015  
Sonya Essaadi of Portland, Oregon, passed away at the end of fall semester from a rare form of bone cancer. During her time at Willamette, Sonya threw herself fully into her education and campus life. Among her many activities, the politics junior served on the university Honor Council, was vice president of member development

for her sorority, Pi Beta Phi, and spent two years as a legislative intern for Oregon state Rep. Alissa Keny-Guyer. In February, Keny-Guyer shared a remembrance of Sonya on the floor of the Oregon State House of Representatives. Sonya is survived by her parents, **Melissa Rose-Essaadi '88** and Abdellah Essaadi, and sister, Sarah.

## FORMER FACULTY

#### **Dr. William Z. Iron Jr., PhD**

Feb. 4, 1926 – May 12, 2015  
William Zachariah Iron was born in Idaho and raised on a ranch outside of Twin Falls. During World War II, he joined the U.S. Navy and served on a cruiser in the South Pacific. After his discharge, Bill graduated from Linfield College and went on to teach high school English, speech and drama. After earning his master's degree and a doctorate in theatre arts from the University of Oregon, he returned to teaching, first at Lewis & Clark College and then at Willamette, where he served as the theatre department chair until his retirement in 1991. Bill enjoyed traveling, playing chess, reading and writing. Survivors include children Sherrideth, Danna Lou and Patricia; second wife, Katherine; and stepchildren Jennifer and Gary.

## FORMER STAFF

#### **Clyde B. Spence**

April 24, 1933 – Nov. 16, 2015  
Clyde Spence was born in West Virginia to a coal-mining family. He joined the U.S. Army and served in the Korean War, where he suffered substantial frostbite on his feet and hands. After the war, he was stationed in Grand Forks, North Dakota, before being honorably discharged in 1976. While in North Dakota, Clyde met the love of his life, Constance. Married on Nov. 12, 1976, the couple eventually moved west to Salem, Oregon, where Constance had spent her childhood summers. Both were employed by Willamette University from 1979-1994, Clyde in maintenance and Constance as secretary to the president. The couple had no children, and Constance died in May 2007. A familiar and popular figure on campus Clyde established two scholarships, one for the College of Liberal Arts and the Clyde B. and Constance B. Spence College of Law Veterans Scholarship Fund.

# In a Single Garment of Destiny

By Leonard Pitts Jr.

**Martin Luther King Jr.** said frequently, “Injustice anywhere is a threat to justice everywhere. We are caught in an inescapable network of mutuality, tied in a single garment of destiny. Whatever affects one directly, affects all indirectly.”

It’s hard to imagine somebody arguing with that. It seems like a self-evident truth. But it raises an obvious question. If all life is interrelated, if you and I are just different threads in a single garment of destiny, why do we find it so difficult to act like it?

The answer, of course, is race. Of all the truly stupid ideas human beings have developed, arguably the most stupid is race. As a scientific matter, by any means of objective quantification, race has absolutely no meaning. As a cultural matter, however, it positively seethes with meaning. It defines privilege, life expectancy, education, crime, faith, health, history, media, interpersonal relationships, banking, employment, entertainment and pretty much every other arena of everyday life.

It shapes who we are and how we see the world. And yet, race is an invention only about three or four hundred years old. Once, it was not defined by skin color and physical appearance, but by geography and climate. People from colder places were believed to be patient and thoughtful. Those from hotter places were said to be impetuous and impatient.

The inhabitants of Europe who began flocking to this land in the 17th century did not regard themselves as “white.” They were Dutch, French, Portuguese, English, Spanish and they had no particular sense of common cause. They were in *contention* with one another to determine who could exploit the riches of this new land.

Similarly, Africans did not regard themselves as black. They were Mandinkan, Songhay, Tuareg, Fulani, Wolof, Mende, Balanta. But when they were kidnapped and taken to America, they learned a new identity. They became Negro. They became black.

As one historian put it, Africans did not become enslaved because they were black. They became black because they were enslaved. In a similar sense, Europeans did not become slave owners because they were white. They became white because they were slave owners.

These two arbitrary designations became the justification for one



group of human beings to elevate itself above another group of human beings, and for the second group of human beings to be treated as if they were not human beings at all.

Each January, you can’t turn on the television without running into that grainy news footage of Martin Luther King standing in front of the Lincoln Memorial saying, “I have a dream.” I think “I Have A Dream” is one of the two or three greatest speeches any American ever gave. Those words are immortal.

But, Martin Luther King did a whole lot more than dream. He worked. He organized. He marched. He strategized. He spoke out. He did so in the cause of African-American freedom, of ending segregation and oppression based on the fiction of race. But also in the cause of

*human freedom.*

His last campaign, the one he was working the day he was shot in the face and killed by a white supremacist named James Earl Ray, was called the Poor People’s March. It was to have been a crusade in Washington to unite the white poor, the Hispanic poor, the Asian poor, the Native American poor, the African-American poor to fight for a living wage and a more equitable sharing of resources.

This country has never lacked what the rapper Chuck D calls “weapons of mass distraction” — those groups we are told to fear. Once, it was the Jews, the Irish, the Poles, the Germans, the Japanese. These days, it’s the homosexuals, the Muslims, the illegal immigrants.

And it has always been the blacks.

It is past time we stopped falling for weapons of mass distraction. It is past time we heard what Martin Luther King tried to teach us about the interrelatedness of life. Black and white, Jew and Muslim, gay and straight, we are all threads in that garment of destiny. And you know how it is with threads: you pull one loose and the whole garment unravels.

We can begin to question the importance we attach to all these barriers and differences. We can, as King taught us, begin to organize, strategize, speak out, and *work* to locate the humanity in those who are not like us. And so, step by painful step, we can vindicate the ideals we hold sacred and dear. ☐

*Leonard Pitts Jr. is a Pulitzer Prize-winning syndicated newspaper columnist, novelist and commentator. This article is excerpted from a speech he gave at Willamette on Feb. 5 as part of the university’s events celebrating the legacy of Rev. Dr. Martin Luther King Jr.*

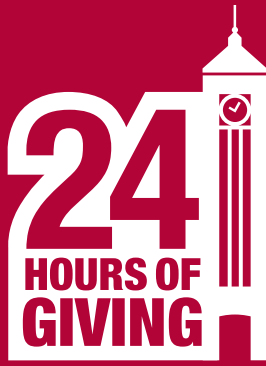

**SPECIAL THANKS** to everyone who helped make the second annual "24 Hours of Giving" initiative a success! The collective commitment to the well-being of the Willamette community is truly inspiring and deeply appreciated. #WU24

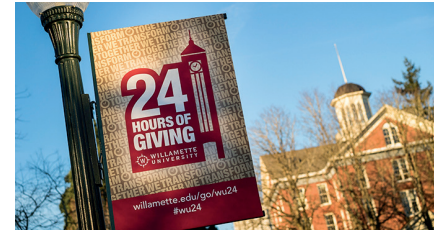

## Explore the World with Fellow Bearcats!

The Bearcat Explorers travel program offers alumni, parents and friends the opportunity to explore the world near and far while continuing the pursuit of lifelong learning and connections — with the university and each other.

See more at [willamette.edu/go/explorers](http://willamette.edu/go/explorers)



### Rogue River Whitewater July 14-16, 2016

Enjoy three days of fun and Bearcat camaraderie on the Rogue River in southern Oregon. Navigate the river's Class 3 rapids and then relax at wilderness lodges, complete with comfy beds, private bathrooms and delicious meals.



### Grand Norwegian Coastal Voyage Oct. 3-17, 2016

The Norwegian fjords' beautiful scenery is even more striking in the fall, making this a great time to take an 11-night cruise. The journey along the pristine coastline will take travelers to unspoiled fishing villages, quaint historic towns and a crossing of the Arctic Circle to Europe's northernmost point.



### Shakespeare on a Budget — Ashland Oct. 22, 2016

Meet alumni, current students and theatre professor Jonathan Cole in Ashland, Oregon, for the annual Shakespeare Festival. Bearcats enjoy two plays and a group meal at an unbeatable price.

### Two Ways to Visit Cuba!

**By Sea: Jan. 14-21, 2017**

**By Land: Jan. 29-Feb. 7, 2017**

Enjoy this once-forbidden gem via a luxury cruise on a beautiful yacht over 8 days, or a 10-day land tour.

### Tanzania — Safari & Red Sweater Project February 2017

Enjoy a safari expedition and special Willamette connections with Carrie O'Callaghan '00 and Ashley Holmer '02. Optional Kilimanjaro climb add-on.

### Croatia and Pearls of the Adriatic Coast May 18 - June 1, 2017

Springtime cruise along the spectacular Adriatic coast aboard a luxury yacht for 26 WU passengers! Attractive pre- and post-trips available to Montenegro and Slovenia.

# YOUR INSTA-WILLAMETTE FIX



**For Bearcats far from Salem, the power of social media can bring back all the Willamette sights — and feelings. This is what's happening on campus now: spring puddles, fuzzy ducklings and the bluest of skies. To get your Willamette fix year-round, follow us on Instagram and Twitter @willamette\_u.**

[willamette\\_u](#)

